

LG HVAC SOLUTION
CENTRIFUGAL CHILLER

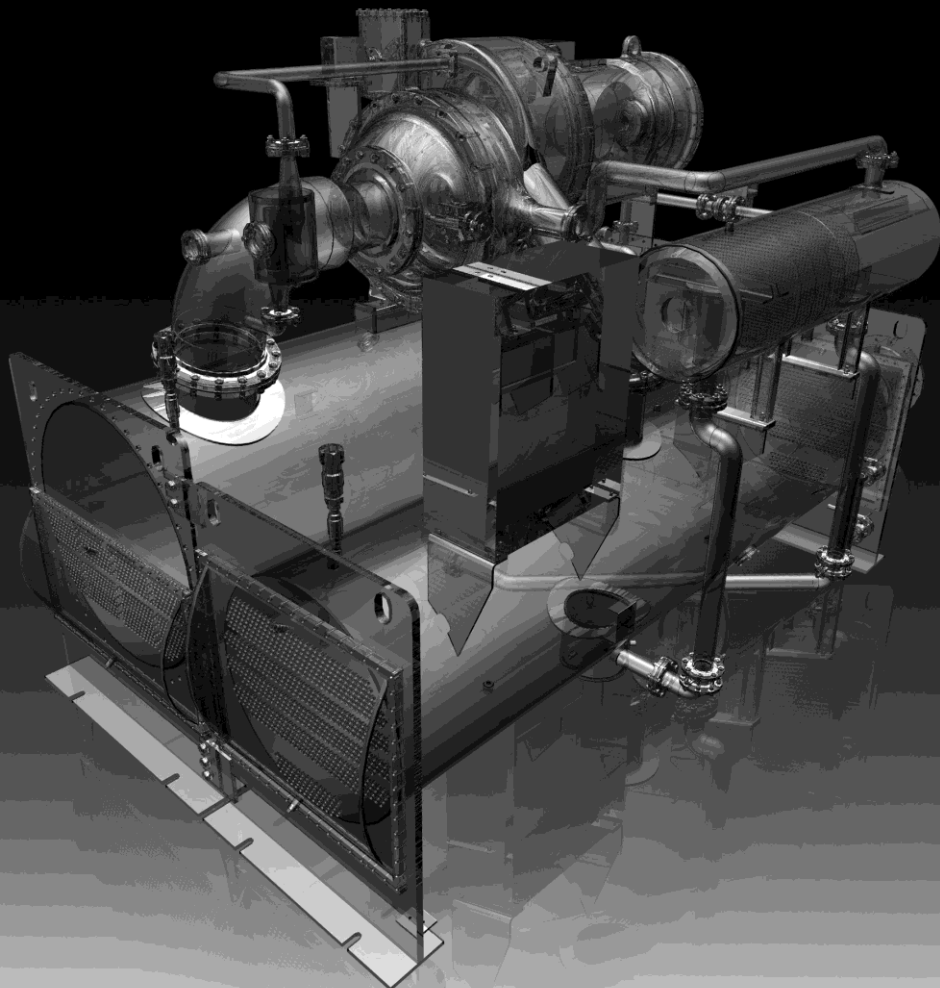

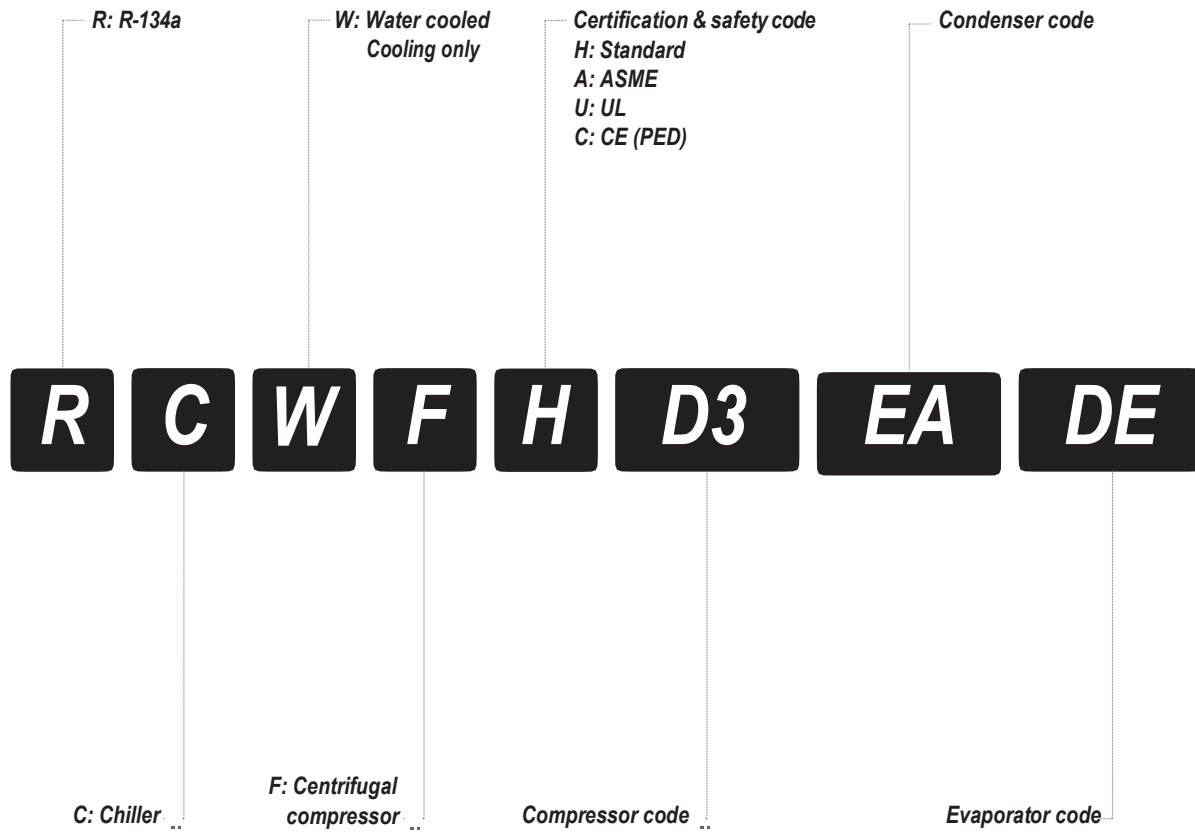

Contents

- 02 Nomenclature
- 03 Line up & Introduction
- 04 Equipment overview
- 07 Controls
- 11 Refrigerant cycle
- 11 Lubrication system
- 13 Safety devices
- 14 Options
- 15 Machine components
- 19 Performance data
- 20 Electrical data
- 24 Field wiring
- 24 Typical piping & Wiring
- 25 Piping drawing
- 27 Insulation
- 28 Guide specification

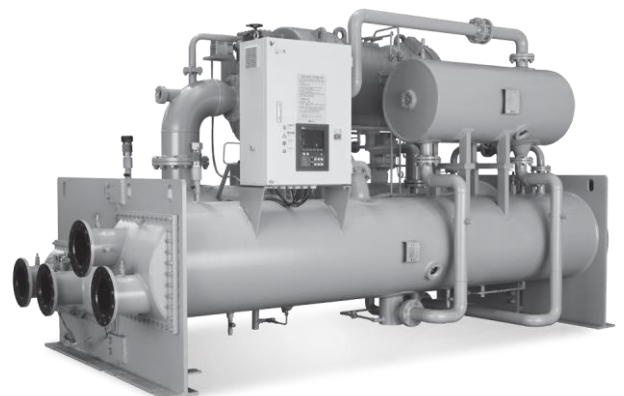

Line up

Model	100	200	300	400	500	1,000	2,000	3,000	4,000
 <p>R-134a 2-Stage</p>		200RT						2,950RT	

* The above range is based on the nominal tonnage.

World class high efficiency

The advanced technologies of LG achieve the lowest energy consumption and preserve the environment.

LG chiller offers high-efficiency chlorine-free water-cooled centrifugal chillers using HFC-134a refrigerant. Over three decades of chiller manufacturing and experience in HVAC industry, it has significantly reduced the power consumption of centrifugal chiller with positive-pressure refrigerant HFC-134a, and introduces most cost effective & reliable solutions to all valuable customers. hydraulic-head loss rate, helps to minimize energy loss even further.



New solution for saving energy

The chiller using a two stage compressor developed by the technology of LG increases energy efficiency by 10% ~ 13% at full load conditions as compared to the chiller with single stage compressor, and increases energy efficiency under partial load conditions by 24% or more.

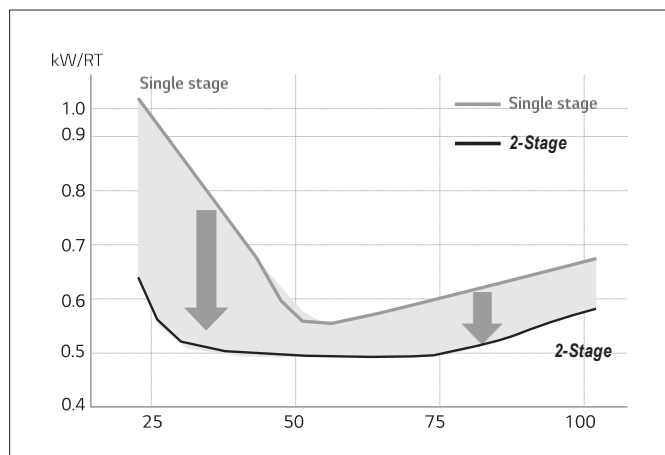

Eco-friendly chiller

The LG chillers use chlorine-free HFC-134a refrigerant having zero ozone-depletion potential and no phase-out date. LG chiller will work as an excellent harmony with environmental friendly facilities.

Saving installation space

LG's optimized chiller design using positive pressure refrigerant minimizes the machine room space and so return a valuable extra space and a cost saving to the customers.

Simple bolting construction

The evaporator, condenser, and compressor are final-assembled with simple bolting and flange connections, LG chiller provides an excellent solution for the retrofit and replacement jobs where are critical difficulties in an installation works within a limited space.

High reliability

LG chillers are designed through 3-dimensional and various dynamic analysis and it increased the reliability.

All components were reliable test and also exclusively selected and manufactured. Factory-run-test are available for all chillers to make sure quality ensurance before factory out as an option by customers.

Optimized & user-oriented control

LG unit controller, LGC-X30 was developed based on advanced algorithm, convenient and reliable control concept.

Also it provides various customer-oriented functions; graphical display of key data, operation scheduling, help menu for easy trouble shooting, three language support, various industrial standard interface protocols and more.

AHRI certification program

LG chillers has been certified to the air conditioning and refrigeration Institute (AHRI) as complying with the certification sections of the latest issue of AHRI Standard 550/590.



Under this certification program, chillers are regularly tested in strict compliance with this standard. This provides an independent, third-party verification of chiller performance.

Standards and codes

- AHRI 550/590 - Water chilling packages using the vapor compression cycle.
- ANSI/ASHRAE 34 - Number designation and safety classification of refrigerants.
- ASME section VIII - Boiler and pressure vessel.
- CE - Conform to CE testing services for construction of chillers and provide CE listed mark
- GB/T 18430.1 - Water chilling (Heat pump) packages using the vapor compression cycle - Part 1: Water chilling (Heat pump) packages for Industrial & commercial and similar applications.
- GB25131 - Safety requirements for water chillers (Heat pump) using the vapor compression cycle.
- GB150/151 - Steel pressure vessels/tubular heat exchangers.
- ANSI/ASHRAE Standard 15 safety code.
- Manufactured in an EN ISO 9001 accredited organization.
- ETL – Conforms to ANSI/UL STD 1995 certified to CAN/CSA STO C22.2.
- N.E.C. – National electrical code.
- OSHAS 18001 – Occupational safety and health act.



Unit performance test

LG has established one of the largest chiller testing facility in the world.

Each LG chiller is thoroughly tested prior to shipment, and is delivered to the customer with full test data included.

Performance test facilities are able to test up to 3,000RT, 13.8kV and also available to accurately recreate a wide variety of environmental conditions, helping the company to tailor its products to the greatest number of markets.

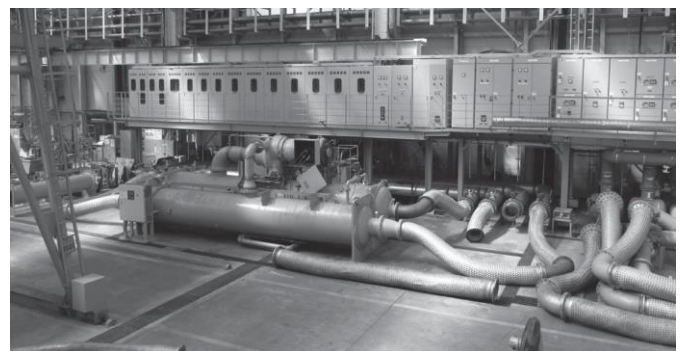

Performance test facilities

Equipment overview

Two stage compressor design

LG Chiller uses simple, compact and economic two stage design with two impellers, variable diffuser and economizer. When operating at light loads with high condensing temperatures, it happen unstable operation, called "surge". But two stage compressor is avoided with two stage design because two stage compressor has wide range of operation. Twostage compressor is possible to flash refrigerant gas at two intermediate pressures between the evaporator and condenser, significantly increasing chiller efficiency. The improvement of efficiency is not available for single stage chiller because all compression is done by single impeller.

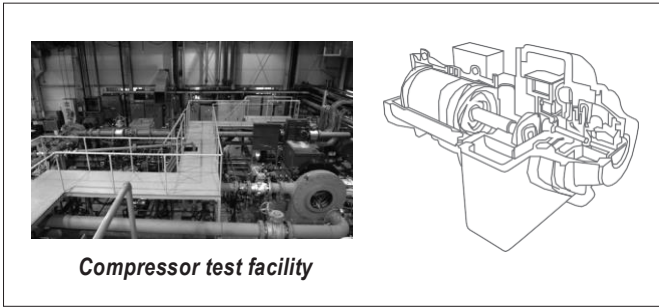

Compressor test facility

Inlet guide vanes

LG chiller adopts IGV (Inlet Guide Vanes) for the capacity control.

However, the vane opening is precisely controlled by a modutrol motor. Precise and smooth control of the chilled water temperature can be confirmed with this simple device. It adjusts the refrigerant mass flow rate taken through the compressor inlet to adjust the capacity of the chiller, and it adjusts the opening of the vanes using the external actuator. The amount of refrigerant taken in is adjusted according to the set of chilled water outlet temperature.

Variable diffuser

Enlarges the safety operation range at a low-load condition, and prevents surge by applying a variable diffuser.

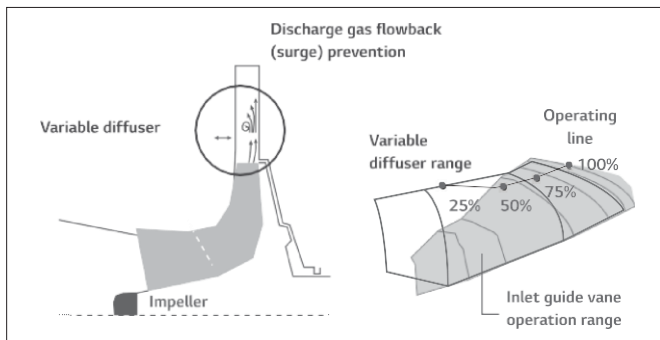

Bearing

1. Compressor type : A0 ~ E3

- Ball bearing is composed of isolated bearing on motor axis and angular contact bearings on the impeller axis.
- Ball bearing structure is subjected to a radial and axial load at the same time.
- Because oil supply flow in ball bearing structure is small, the rotation system is more compact design.

2. Compressor type : F1 ~ G3

- Bearing is composed of bearing in motor axis, radial bearings and thrust bearings on the impeller axis.
- Bearing are made out of white metal to achieve persistence and corrosion resistance. By designing to lubricate to radial bearing and thrust bearing it can avoid the metal to metal

contact during the operation.

- To increase the reliability of the journal bearings, Offset type and 3-Lobe type bearings are applied.

Aerodynamically-contoured impeller

Impellers that utilize 11 back sweep main blades and 11 splitters are aerodynamically contoured to improve compressor efficiency. The blade 3D profiles are designed by using 3D- CFD (Computational Fluid Dynamics) and design database based on compressor tests.

- The vane of impeller designed aerodynamically based on the 3D fluid analysis, guarantees the reliability in any operational condition.
- To minimize vibration, the impeller took dynamic balancing work. It also guarantees the overall reliability of the impellers by taking the strength test, hardness test, non-destructive test, etc. for every impellers produced.

Low solidity airfoil diffuser

Using simple 2D airfoils, the low solidity diffuser increases compressor peak efficiency and widen operating range with no moving parts.

Robust rotor dynamic system and transmission

High speed rotating system including bearings are designed to confirm the robust operating over the life of the machine at various load conditions.

Oil pump

The oil pump is driven by an electric motor from the separate power source to prevent the lubrication failure due to abnormal compressor shutdown. It delivers fluent oil to the gears and the 4 bearings when compressor start-up and normal operation.

Oil heater

High speed rotating system including bearings are designed to The oil heater installed in the oil sump is mainly used to dry out the refrigerant mixed in the reclaimed oil from the transmission and the evaporator. Also, the heater prevents the abrupt mix of oil and refrigerant while compressor shutdown and pre-heats the oil before start-up. All the operation of the heater is controlled by the microprocessor controller.

Oil cooler

A compact refrigerant-oil heat exchanger is used for the oil cooler. The liquid refrigerant is safe and effective cooling source in the system. A small amount of liquid refrigerant is extracted at the bottom of the condenser and it cools the

hot oil (after lubricating the transmission system) at the heat exchanger and returns to the evaporator.

Oil reservoir

During the power failure, oil reservoir shall automatically supply oil for compressor bearings to prevent any compressor damage.

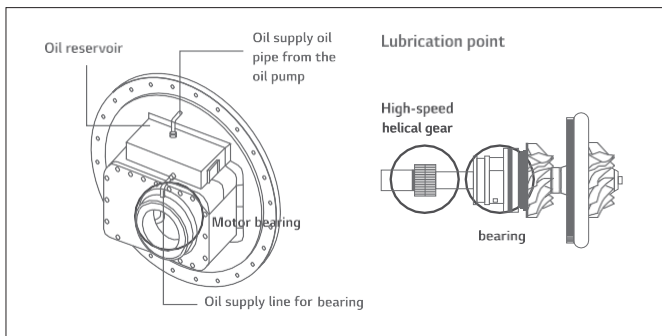

Refrigerant-cooled Semi-hermetic Motor

The motor is bolt-connected to the compressor gear housing and the shaft labyrinth seal prevents refrigerant leakage from the motor to the gear box. This semi-hermetic motor is more compact and makes less noise than the air-cooled motor. No heat is ejected to the machine room. No expensive mechanical seal is required. Using motor shaft as a bull gear shaft, no coupling is needed and it minimizes the shaft alignment problems. Like oil cooler, the motor is cooled by the condensed liquid refrigerant. The liquid refrigerant is sprayed to the several stator locations of the motor for efficient cooling. The optimum locations and the liquid flow rate is designed by a lot of motor tests.

Heat exchangers

Heat exchanger of two-stage centrifugal chiller is composed of two shell type for easy separation into evaporator and condenser. The tubes are arranged so as to maximize the heat exchanging ability. It is also designed so that the refrigerant can be spread evenly on all tubes for the sake of surge prevention and the COP decrease in part load operation.

Efficiency increasing purpose sub cooler is adopted for the subcool of the condensed refrigerant.

A relief valve for an abnormal situation is at the upper part of the heat exchanger.

High performance tubes

Heat transfer coefficients on inner surface are significantly enhanced by selecting optimal ridge size and angle without sacrificing pressure drop. In addition, Enhancement of heat transfer on outer surfaces are respectively designed and tested for easy condensation and evaporation.

Effectively-designed Condenser

LG condenser has a baffle to prevent direct impingement of high-velocity refrigerant gas on the tube surface and thus eliminate the related vibration and noise. Entering condenser water flows into sub-cooler from cooling tower and then flows through the upper part of condenser tube. This helps to lower the condensing temperature and thus reduce consumption of compressor power.

Durable heat exchanger

Expansion of tube in double-grooved hole at tube support prevents leakage and increases durability of heat exchanger.

Isolation valves of refrigerant filter

This valve allows us to replace filter without pump-down of refrigerant. This is installed for less service time and less expense.

Pressure vessel (options)

The evaporator and condenser can be provided with either ASME or PED pressure vessel codes certification.

Expansion device and economizer

The condensed refrigerant liquid passed the 1st expansion device enters the economizer which divides into refrigerant gas and liquid. The refrigerant gas is mixed with mid-temperature, mid-pressure gas compressed in the 1st impeller. The refrigerant liquid goes through 2nd Expansion device to be taken into evaporator. The mid-temperature and mid-pressured gas between the 1st and the 2nd impeller become cool by mixing with the cool refrigerant gas supplied from economizer before sucked in to the 2nd impeller. As such, when the 2nd impeller discharge gas temperature is decreased by decreasing 1st impeller discharge gas, the power required by the compressor is decreased-increasing the cycle efficiency. The efficiency increase much higher than by the 1 Stage compressing method.

Microprocessor-based controls

LG's Microprocessor-based controller, LGC-X30 enables the user to monitor and control the chiller with high-class accuracy and confidence. The exclusively designed algorithm allows the optimized operation.

LGC-X30 controller is ready for multi-language support; Chinese, English and Korean.

LGC-X30 has 100% H/ W compatibility and freely interfaced with LG Absorption Machine.

Max. 8 units of LG chiller can be linked together and controlled through only 1 protocol converter.

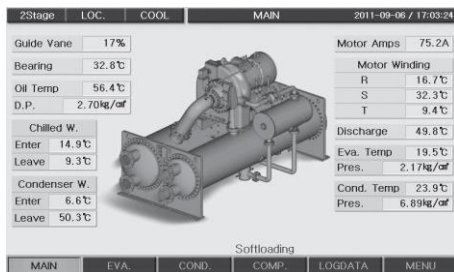
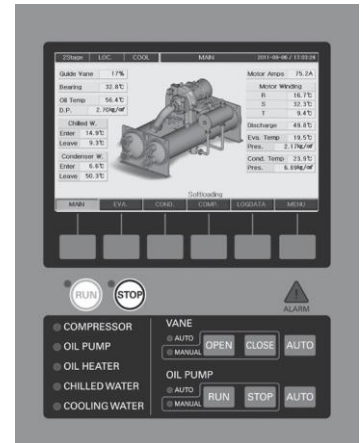

7" Color LCD with high resolution

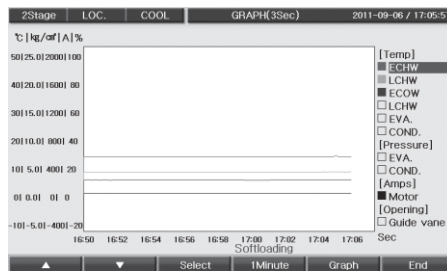

Operation data trend

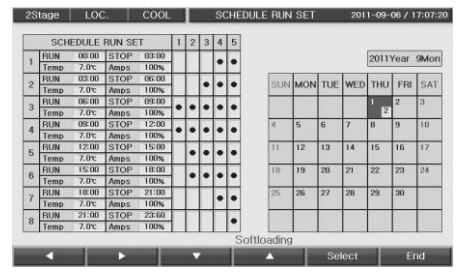

Reserve operation

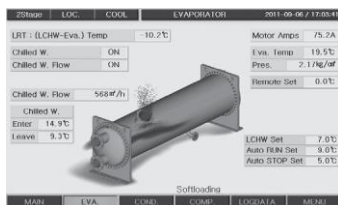

State of evaporator

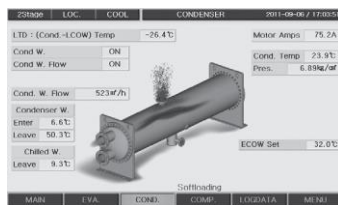

State of condenser

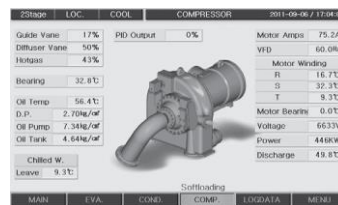

State of compressor

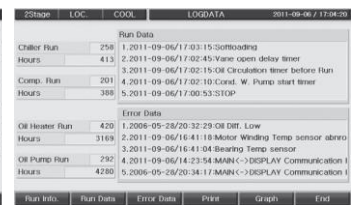

Operation history

AC Smart premium

- 10.2-inch color LCD screen with high resolution (1,024 x 600)
- Operation scheduling function
- Real time trend display
- Web Access
- Running data acquisition
- Easy-to-read display of operational data
- Certified EMI/EMS
- Communication supported: RS485 (standard) and Ethernet (optional)
- Language: English / Chinese / Korean
- Auto-printing function (optional)



Microprocessor controls

The unit controller is factory mounted, wired and tested before shipment. And a built-in printer, BACnet™, MODBUS™ protocol converter module and Modem are equipped as an option.

Safety cutouts

The all safety control inputs and, if required, shuts down the chiller or limits the guide vanes to protect the chiller from possible damage from and of the following conditions:

- High bearing temperature
- High motor winding temperature
- High discharge temperature
- Low oil pressure
- Low cooler refrigerant temperature/pressure
- Condenser high pressure or low pressure
- Inadequate water cooler and condenser flow
- Excessive motor acceleration time
- Excessive starter transition time
- Lack of motor current signal
- Excessive motor amps
- Excessive compressor surge
- Temperature and transducer faults
- Soft start system
- Soft stop system
- Control circuit fuse
- Control module fuse
- Oil heater fuse
- Oil pump motor fuse
- Safety relief valve

Main menu indications (Control center)

- Run Mode Set
- User Set
- Manual Control
- Schedule Set
- Service Menu
- Run Data Check
- Error Data Check
- Pager Mode Set
- System Menu
- Bright Control

Basic display items

- Chilled water inlet & outlet temperatures (°C)
- Cooling water inlet & outlet temperatures (°C)
- Compressor discharge temperature (°C)
- Compressor bearing temperature (°C)
- Oil tank temperature (°C)
- Motor windings (R.S.T) temperatures (°C)
- Evaporator pressure (kg/cm²)
- Condenser pressure (kg/cm²)
- Oil tank pressure (kg/cm²)
- Oil pump pressure (kg/cm²)
- Amperes (A)
- Voltages (V)
- Watts (kW)
- Chilled water flow (m³/h) fR
- Cooling water flow (m³/h) fR
- Vane openings (%)
- Remote setting temperature (°C)
- Evaporator temperature (°C)
- Condenser temperature (°C)
- Differential pressure of oil (kg/cm²)
- Hot-gas valve output (%)
- Frequency of cooling tower fan inverter (Hz)
- PID output (%)
- Control output (%)
- Real setting value (°C)

• These items are optional.

User settings

- Chilled outlet temperature (7°C)
- Compressor current limit (100%)
- Guide vane high limit (50%)
- Cooling mode P & I & D (6.8°C, 300 sec., 3.0 sec.)
- Hot-gas valve- Vane % (30%)
- Hot-gas valve max. (100%)
- Hot-gas valve min. (0%)
- Chilled water brine temperature (-5.0°C)
- Cooling tower fan RUN (32.0°C)
- Cooling tower fan STOP (28.0°C)
- Cooling tower fan STEP (1.0°C)
- Cooling tower fan delay (60sec)
- Cooling water inlet temperature (31.0°C)
- Cooling tower fan P & I & D (4.0°C, 400sec, 20.0 sec.)
- Operational data log time (60 sec.)

- Year
- Month
- Date
- Week
- Hour
- Minute
- Second
- LCD light on time (60 sec.)

• The values in () are default setting values.

Main menu indications (Control center)

- Run Mode Set
- User Set
- Manual Control
- Schedule Set
- Service Menu
- Run Data Check
- Error Data Check
- Pager Mode Set
- System Menu
- Bright Control

Control sequence

Start

The chiller is starting to run by pressing the RUN-key on the control center of unit controller; the key must be pressed for 2 seconds as a minimal. During the manual operation, RUN type must be set as "local mode" second start-up will only activate 30 minutes (expiration of re-start prevention timer) after normal-start or 3 minutes (expiration of starting oil pump circulation timer) after auto-stop in order to protect compressor.

Firstly, the chilled water pump is energized, and then the cooling water pump is energized 5 seconds later. And the chiller will proceed to next sequence only after chilled water and cooling water flows reach the limits. If the chilled water temperature is 2°C less than setting temperature, only the chilled water pump will run.

Once the chiller started, the compressor starts from the soft-loading mode to open the vane slowly in order to prevent rapid increase of power consumption. Then the capacity control follows. When the troubles occur after compressor energized, the compressor stops, and the alarm lamp is on, and the shutdown status is displayed on the LCD, and also shutdown

information is recorded into the RAM of controller.

Stop

The chiller stops under one of the following events:

- The Stop button is pressed for at least 2 seconds or the remote-stop signal is delivered to the controller.
- Auto-stop at "Setting temperature - 2°C"
- Time schedule is stop-mode
- Alarm states

During the stop process, firstly the compressor is forced to stop. The guide vane is brought to the closed position. The oil pump and chilled water pump stop 300 seconds after the compressor stops. The cooling water pump will stop. And 3 minutes of starting oil pump circulation timer will count down.

If the stop button is pressed or remote-stop signal is delivered, the guide vanes will close. And the chiller will stop, if the vane full-close limit switch is closed or the vane opening is less than 10% or 4 minutes passed from that the vane starts to close.

Re-start

Restart is activated only after the followings;

- After expiration of re-start prevention timer (30 minutes)
- After expiration of starting oil pump circulation timer (3 minutes)

If the chiller stop due to a safe-stop, the reset button must be pressed before restarting the chiller.

increase of power consumption. Then the capacity control follows. When the troubles occur after compressor energized, the compressor stops, and the alarm lamp is on, and the shutdown status is displayed on the LCD, and also shutdown information is recorded into the RAM of controller.

Various interface solutions

Using industrial standard protocol converters, the chiller can be interfaced with BAS (Building Automation System).

The remote monitoring and control of the chillers is possible via BACnet™/Ethernet, BACnet™/IP, MODBUS™, Modem or RS-232C/RS-485.

Advanced PID control

The advanced algorithm provides an optimum control during the chiller starts, stops and even normal-operation. The advanced PID control minimizes the overshoot and undershoot during the chiller starts and normal operation, and also enables accurate and quick response to temperature control.

Chilled water temperature reset

The chilled water temperature can be reset locally or remotely to readjust the chilled water outlet temperature and save energy.

Operation scheduling

The user can program the chiller operation schedule to run and stop the chiller automatically during the absence of the operator.

Soft loading

At the start-up, the vane opening is controlled with gradual slow-open to prevent surge, oil foaming and finally to protect compressor. This control lasts until the chilled water temperature reaches the target value.

Preventive control

The preventative control is executed before abnormal-stop point and so unnecessary chiller-stops can be minimized.

Various interface solutions

Using industrial standard protocol converters, the chiller can be interfaced with BAS (Building Automation System).

The remote monitoring and control of the chillers is possible via BACnet™/Ethernet, BACnet™/IP, MODBUS™, Modem or RS-232C/RS-485.

Advanced PID control

The advanced algorithm provides an optimum control during the chiller starts, stops and even normal-operation. The advanced PID control minimizes the overshoot and undershoot during the chiller starts and normal operation, and also enables accurate and quick response to temperature control.

Chilled water temperature reset

The chilled water temperature can be reset locally or remotely to readjust the chilled water outlet temperature and save energy.

Operation scheduling

The user can program the chiller operation schedule to run and stop the chiller automatically during the absence of the operator.

Soft loading

At the start-up, the vane opening is controlled with gradual slow-open to prevent surge, oil foaming and finally to protect compressor. This control lasts until the chilled water temperature reaches the target value.

Preventive control

The preventative control is executed before abnormal-stop point and so unnecessary chiller-stops can be minimized.

Direct control of peripheral equipment

It is possible to control chilled/cooling water pumps and cooling tower fan with direct connection with LG unit controller. The cooling tower fan can be 4-step controlled or PID-controlled, the inverter applied.

Self-diagnosis and help function

Self-diagnosis is always performed before start-up and enables safe operation. And the help function informs the user a proper action to be taken if problem occurs.

Data acquisition & storing

Maximum 300 records of operational data including alarm status can be accumulated. And the data collection interval can be set with every 1 second interval from min. 5 seconds to max. 360 seconds and the alarm data is always stored regardless of setting interval.

Graphical display

Various key data is also displayed graphically and so the user acknowledge the data trend with very convenient and ease.

Built-in printer (option)

The built-in printer allows the user to check and keep the operational data with hard-copy format.

Password protected

Unauthorized access to the control is protected with random-generated password.

Communication protocol support

- Communication method
 - Basic: RS-485, Ethernet(option)
- Protocol
 - Basic: MODBUS
 - Option: BACnet, TCP/IP

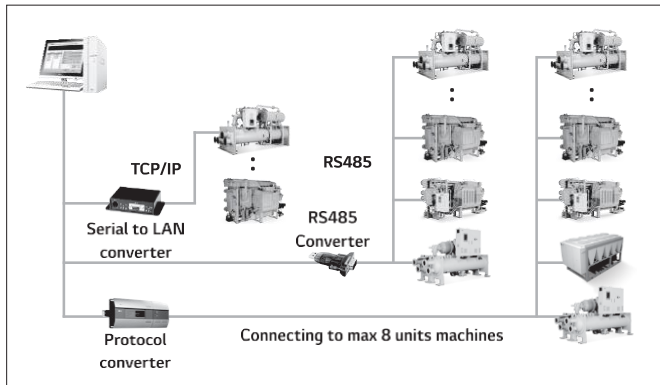

Refrigerant cycle

The two Stage Centrifugal chiller uses environment friendly high pressure refrigerant R-134a.

- In this cycle, as shown in the figure, the vaporized low temperature and low pressure refrigerant gas passes the Inlet Guide Vane, and enters the 1st impeller of the compressor. Since the inlet gas amount is dependent on the guide vane's opening, the chiller capacity can be controlled.
- Refrigerant gas that entered the 1st impeller is compressed to a mid-temperature and mid pressure, passes through the return channel, cooled by low temperature gas from the economizer, and then enters the 2nd impeller.
- The refrigerant gas entered the 2nd impeller is compressed as high-temperature and high-pressured refrigerant gas, and discharged to the condenser. The gas loses its heat via cooling water in the heat transfer tubes and eventually condensed to liquid.
- The condensed refrigerant liquid passed the 1st expansion device, becomes mixed state and enters the lower part of the economizer which divides into gas and liquid of refrigerant. The gas part is mixed with the mid temperature and mid pressured gas which was compressed in the 1st impeller, and then enters the 2nd impeller. The liquid part of the refrigerant enters the lower part of evaporator via 2nd expansion device.
- The liquid refrigerant entered into the evaporator, is then spread into wider surface of evaporator by distributor. Finally the distributed refrigerant evaporates by taking the heat from the chilled water inside the evaporator tubes and repeats the cycle.
- Some part of the over-cooled refrigerant liquid in the condenser, flows through the valve, filter, moisture indicator, and enters into the motor and oil cooling system individually.
- The refrigerant liquid flew into the motor is being sprayed so that it can cool the motor's coil and is returned to the evaporator.

- The refrigerant flew into the oil cooling system, flows through the disc-shaped oil cooler. Refrigerant that left the oil cooler is then returned to evaporator.

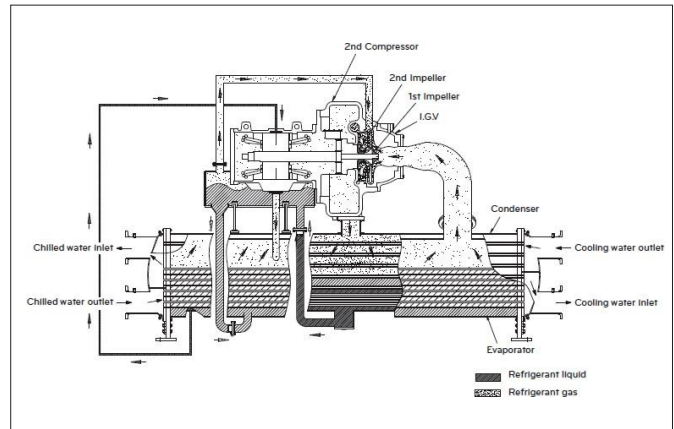

Two stage centrifugal chiller

Lubrication system

Introduction

The discharged lubricating oil by the oil pump enters the oil filter to get rid of any unnecessary foreign substance. This oil becomes cooled to the temperature appropriate for operation condition after through the oil cooler, part of it directly enters gear and high speed side bearings, and the remainder directly enters motor shaft bearings. After the process, it will be drained into the oil tank. The above figure shows the lubrication system of two-stage compression type.

Lubrication cycle

Lubricating oil is forwarded through the manual oil charge valve to the Lubrication System. Oil level can be detected through a sight glass on the oil tank. During the operation, the level should be able to be detected at least from one of them. The temperature of the oil tank is indicated on the control panel and its temperature is below 85°C while operating. What the oil pump does is to transfer the oil from the oil tank to the system and the adequate pressure different would be 0.8kg/cm² that is maintained by the oil pressure controller. The differential pressure can be seen on the control panel pressure gauge display by the differential pressure between oil tank and oil pump. The oil pump also helps to send the oil to the oil filter.

A valve is installed at the oil filter so that no need to drain the whole oil when replacing the filter only. After the oil is sent

to the oil cooler it is cooled by the refrigerant flowing from the condenser. The refrigerant cools the oil at the temperature below 74°C. A part of the oil flows through the bearing and gear spray, whereas the rest lubricates the motor shaft bearings and the radial bearings.

The oil temperature in the oil tank is measured by temperature sensor and displayed. The timer automatically activates the oil pump for 120~180 seconds to maintain a constant pressure first before starting compressor. After the system has been shut down, 300~600 seconds lubricating is taken place after the compressor is stopped.

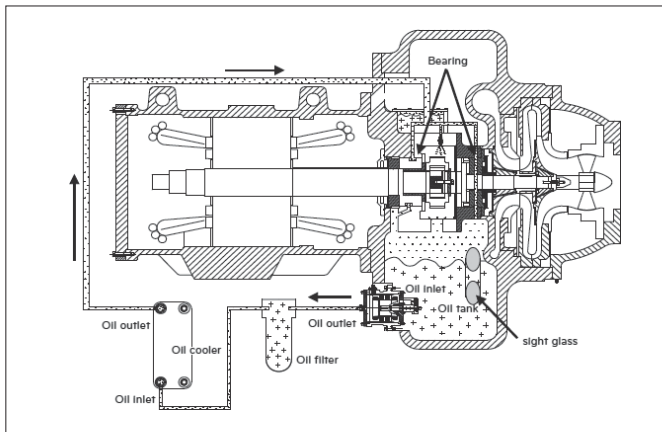

Lubrication cycle

Oil reclaim system

Oil reclaim system provides the system to reclaim the oil from the heat exchanger and let it come back to the oil tank. Normally, it is reclaimed at the evaporator, and the vane housing.

Maintenance

Most of the lubrication related deficiencies in rotating parts of the chiller are because of the oil itself. If adequate viscosity, pressure and flow are not obtained, lubricating performance will decrease. Impure substances that are present in the oil also are a cause for the deficiencies. Freon type refrigerant have chemical attraction with the oil.

The viscosity changes according to the temperature and pressure of oil. We have designed the chiller with these problems into consideration. An oil pump run by hermetic electro motor and a heater controlled by the controlling device are installed in the oil tank to prevent the trouble caused by

the refrigerant inflow into the oil, decrease of the viscosity, damage of the pump caused by the cavitation (vaporizing of water and formation of bubbles as becoming partially low pressurized when water or flow at high speed) and the oil inflow into the refrigerant by forming.

For these reasons the oil tank is maintained at a high temperature. The reason to start the oil pump for certain while before the startup of the chiller, is to prevent the compressor's initial unsteady operation because the left over oil in bearings or in the oil line may contain significant amount of refrigerant flow in during the stoppage. After the chiller has been shut down, oil pump will be operated until the compressor is totally stopped since the compressor rotates due to the internal force. The only action that can be taken to prevent lubrication inferiority caused by blazing of the oil is replacing the oil itself. Thus when it is time for cooling operation, make sure that you do the oil replacing adequately.

Safety devices

For the sake of safe operation and the protection of the chiller, safety devices are ready as the next table.

No.	Safety Devices	Installation Location	Measurement Item	Description	Quantity
1	Chilled Water Temperature Low	Chilled water inlet nozzle	Chilled water inlet temperature	Chiller stops operation if the chilled water outlet temperature below 3 °C to prevent freezing of the chilled water. Do not change this set value.	1
2	Evaporator Pressure Low (Temperature Low)	Evaporator shell	Vaporizing pressure (temp.)	If the pressure inside of evaporator reaches below of the following table, then the chiller stops operation. Standard set value 1.95kg/cm ²	1
3	Condenser Pressure High (Temperature High)	Condenser shell	Condensing pressure (temperature)	If the pressure inside of condenser reaches above of the following table, then the chiller stops operation. Standard setting value 10.00kg/cm ²	1
4	Motor Temperature High	Motor coil	Motor coil temperature	To prevent the motor of the compressor, temperature sensors were installed on each phase of coil and when the temperature exceeds 90 °C, the chiller stops operation.	3
5	Compressor Temperature High	Compressor outlet	Compressor discharge temperature	If the discharging gas temperature of the compressor exceeds over 70 °C, the chiller stops operation.	1
6	Bearing Temperature High	Thrust bearing	Bearing temperature	Temperature sensor is installed on the thrust bearing that holds the impeller's thrust. Chiller will stop operation if the temperature exceeds 85 °C.	1
7	Oil Differential Pressure Low	Oil tank, oil pump outlet	Differential pressure of supplied and intake oil pressure	If the differential pressure between the oil pressure supplied to the bearing and the oil pressure in the oil tank is below 0.8kg/cm ² , the chiller will stop the operation.	1
8	Oil Temperature High	Oil tank	Oil temperature inside of oil tank	The chiller will stop if the oil temperature in the oil tank is above 74 °C.	1
9	Oil Temperature Low	Oil tank	Oil temperature inside of oil tank	The temperature should be over 30 °C as an initial operating condition to enable the chiller to operate.	1
10	Chilled Water Pump Abnormal	Chilled water header	Chilled water head loss	The chiller will stop if the head loss of the chilled water flow passing through the evaporator tubes decreases so much that the loss head becomes lower than the standard.	1
11	Cooling Water Pump Abnormal	Chilled water header	Cooling water head loss	The chiller will stop if the head loss of the cooling water flow passing through the condenser tubes decreases so much that the loss head becomes lower than the standard.	1
12	Current Limiting Function	Control panel	Current	It is a controlling function of Motor Amps that can be set freely in the range of 40~100% to adjust the current load to the motor of compressor.	1
13	Moisture Indicator	Refrigerant supply pipe	Moisture in the refrigerant	The moisture indicator changes the color depending on the amount of moisture in the refrigerant. When there is no moisture it will be green, but if not it will be yellow. It is the time to change into a new filter if you can see the yellow color.	1
14	Relief Valve	Evaporator & condenser shell	Relief valves	To prevent the accident by unexpected fire, and so on which can cause pressure increase in the chiller, the relief valve will be operated and exhaust the refrigerant into the air if the pressure exceeds more than the standard. If the chiller is used in a closed environment, please install a pipe that starts from the relief valve to the outer air.	1
15	Vane Full Close Interlock	Vane motor	Operability of temperature sensors	To minimize the starting current, it is a function to enable the compressor to operate only after full close of the guide vane installed at the inlet of the impeller.	1
16	Temperature Sensor Abnormal	6 locations including chilled water nozzle	Each temperature sensor	It alarms when temperature sensor is not connected or due to the sensor's own flaw.	1
17	Pressure Sensor Abnormal	4 locations including Evaporator shell	Each pressure sensor	It alarms when pressure sensor is not connected or due to the sensor's own flaw.	1
18	Overload relay	Control panel	Current	If overload is imposed on compressor motor or oil pump motor, it stops the motor.	1
19	Hot Gas Bypass Valve	Evaporator shell, Condenser shell	Guide vane / hot gas valve opening	It prevents frequent start ups at low load, and hot gas bypass valve opens proportionally when vane becomes 30% or lower. At this time, hot refrigerant gas of condenser goes to evaporator and makes certain chiller load to prevent surge and to prevent frequent startup stop of the chiller.	1

Options

Items	Option
Refrigerant charging	✓
Hot-gas bypass	✓
Marine water boxes on the evaporator or condenser	✓
High pressure water side construction (max. 350 psig)	✓
Non-standard tubes (e.g., Cu/Ni, titanium)	✓
Outdoor installation construction (non-hazardous areas)	✓
Special construction for hazardous-area installation	✓
Unit-mounted soft starter (available up to 390kW motor outputs with 440V max.)	✓
Built-in data printer	✓
BACnet™ protocol converter module	✓
Remote unit control panel (max. 1,000m)	✓
Factory-charged refrigerant	✓
Sectional shipment (three parts with interconnection pipe)	✓
Factory-completed thermal insulation	✓
Factory sound attenuation work	✓
Factory performance test with witness	✓
Extended warranty	✓
Starter	✓
• Enclosure protection upgrade (IP54)	✓
• Power factor correction capacitor	✓
• Medium-voltage vacuum circuit breaker (fixed or upgraded to the draw-out type)	✓
• Medium-voltage vacuum contactor switch (upgraded to the draw-out type)	✓
• Surge arrestor	✓
• Ground fault protection for the motor	✓
• Overvoltage protection (motor)	✓
• Undervoltage protection (motor)	✓
• Watt hour meter	✓

Machine outline

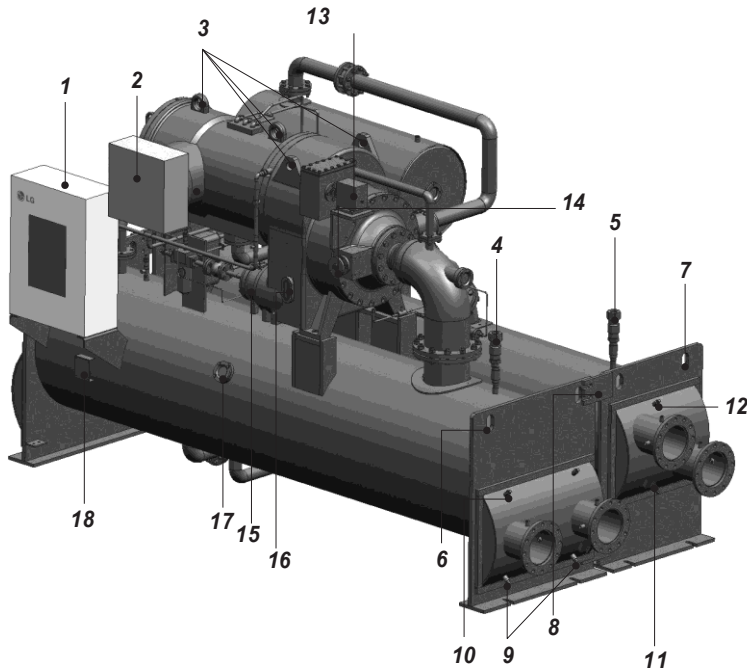

Front view

1. Control panel
2. Motor terminal box
3. Lifting hole for compressor overhaul
4. Evaporator safety valve
5. Condenser safety valve
6. Lifting hole for evaporator
7. Lifting hole for condenser
8. Assembly bracket
9. Drain for chilled water
10. Air vent for chilled water
11. Drain for cooling water
12. Air vent for cooling water
13. Actuator for variable diffuser
14. Actuator for vane motor
15. Oil pump
16. Sight glass for oil tank
17. Sight glass for evaporator
18. Name plate of evaporator

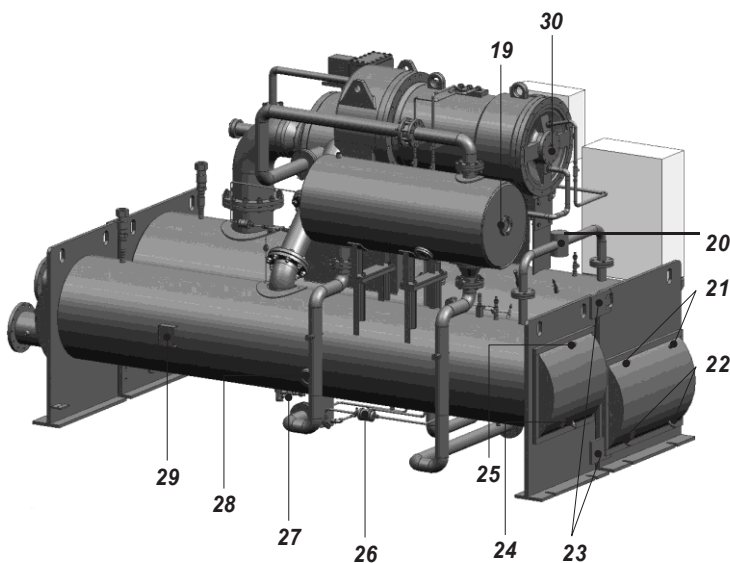

Rear view

19. Sight glass for economizer
20. Hot-gas bypass
21. Air vent for chilled water
22. Drain for chilled water
23. Assembly bracket
24. Drain for cooling water
25. Air vent for cooling water
26. Filter drier
27. Service valve
28. Sight glass for condenser
29. Name plate of condenser
30. Sight glass for checking the motor rotation direction

Dimensions

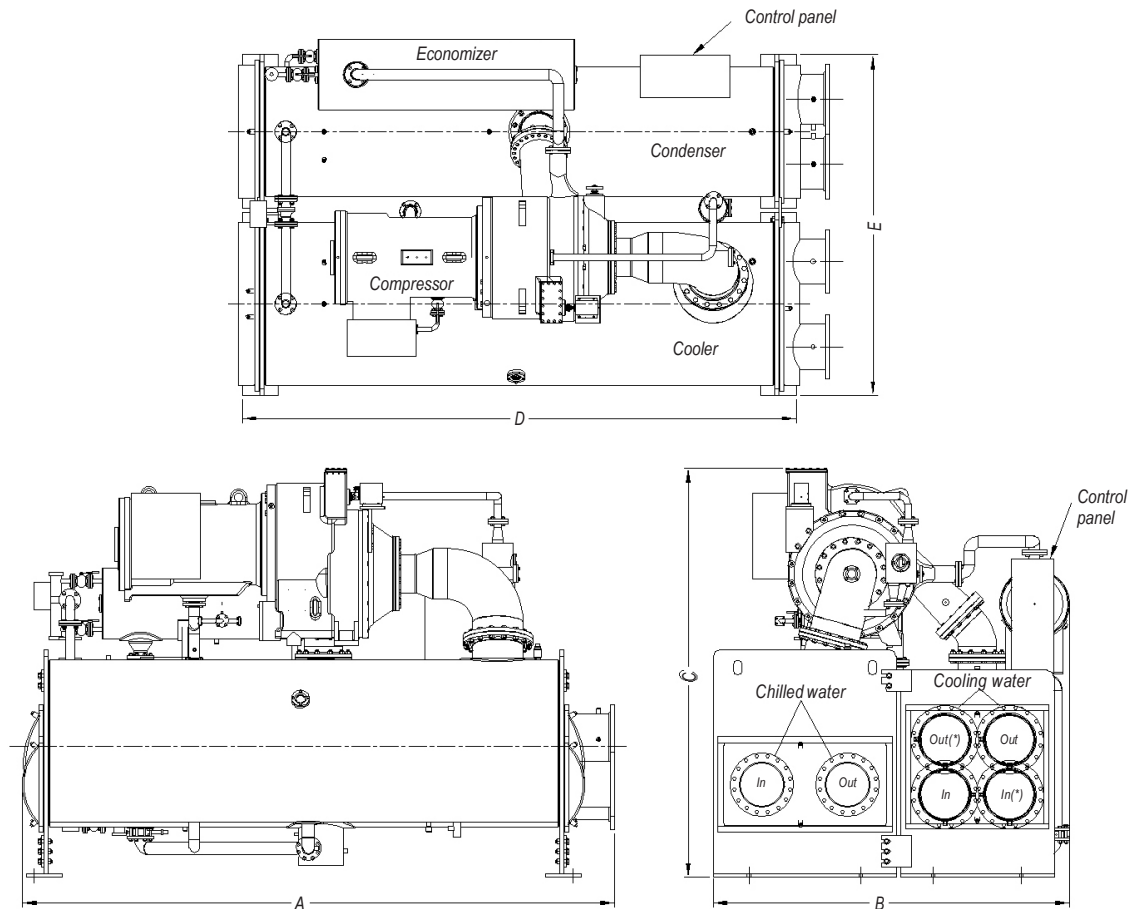

Model	Standard condition				Foot print		Connections	
	(Length)		(Width)	(Height)	D	E	Evaporator	Condenser
	A(2Pass)	A(1,3Pass)	B	C			2Pass	2Pass
RCWFHA1AAAA	3,500	3,700	1,650	2,000	3,250	1,620	150	150
RCWFHB3BCBC	3,500	3,700	2,106	2,280	3,250	1,900	200	200
RCWFHC1BDBD	3,500	3,700	2,106	2,330	3,250	1,900	200	200
RCWFHC3CBCB	3,500	3,700	2,360	2,630	3,250	2,150	250	250
RCWFHD1CFCF	4,150	4,380	2,360	2,630	3,900	2,150	250	250
RCWFHD3DBDB	4,150	4,380	2,510	2,860	3,900	2,390	300	350
RCWFHE1DHDH	4,150	4,380	2,600	3,100	3,900	2,390	300	350
RCWFHE3EBEB	4,700	4,890	3,060	3,100	4,240	2,790	350	400
RCWFHF3GBEK	5,170	5,390	3,830	3,680	4,240	3,020	400	450
RCWFHG3FCFC	6,190	6,410	3,850	3,850	5,680	3,020	500	500

Precautions

- The height is measured from the bottom of the heat exchanger bed.
This value does not include the height of the foundation and the vibration-absorbing pedestal.
- All of the chilled water and cooling water connection flanges are of ANSI 150lb..
- The water pipe facility shall be designed to preventing external force to the chiller.
- The minimum spaces shall be provided around the chiller as follow :
 - Length direction of the chiller: 1,500 mm~2,000mm
 - One of the left and the right side shall be provided with space for Tube replacement.(3,700~6,500mm)
 - Control panel : 1,200mm
 - Others : 1,000mm
- Due to our policy of innovation, some specification can be changed without prior notification

Heat exchangers – Condenser shell codes

No.	Shell length	Evaporator		Condenser		Passes	No.	Shell length	Evaporator		Condenser		Passes
		Code	Shell od (inch)	Code	Shell od (inch)				Code	Shell od (inch)	Code	Shell od (inch)	
1	3,004	AA	30	AA	25	#1,2,3	19	4,004	DH	45	DH	36	#1,2,3
2	3,004	AB	30	AB	25	#1,2,3	20	4,004	EA	50	EA	45	#1,2,3
3	3,004	AC	30	AC	25	#1,2,3	21	4,004	EB	50	EB	45	#1,2,3
4	3,004	BA	35	BA	27	#1,2,3	22	4,004	EC	50	EC	45	#1,2,3
5	3,004	BB	35	BB	27	#1,2,3	23	4,484	EF	50	EF	45	#1,2,3
6	3,004	BC	35	BC	27	#1,2,3	24	4,484	EG	50	EG	45	#1,2,3
7	3,004	BD	35	BD	27	#1,2,3	25	4,484	EH	50	EH	45	#1,2,3
8	3,004	CA	40	CA	30	#1,2,3	26	4,484	GA	60	EJ	45	#1,2,3
9	3,004	CB	40	CB	30	#1,2,3	27	4,484	GB	60	EK	45	#1,2,3
10	3,004	CC	40	CC	30	#1,2,3	28	4,484	GC	60	EL	45	#1,2,3
11	3,654	CF	40	CF	30	#1,2,3	29	5,504	GF	60	EM	45	#1,2,3
12	3,654	CG	40	CG	30	#1,2,3	30	5,504	GG	60	EN	45	#1,2,3
13	3,654	CH	40	CH	30	#1,2,3	31	5,504	GH	60	EO	45	#1,2,3
14	3,654	DA	45	DA	36	#1,2,3	32	5,504	GJ	60	EP	45	#1,2,3
15	3,654	DB	45	DB	36	#1,2,3	33	5,504	GK	60	EQ	45	#1,2,3
16	3,654	DC	45	DC	36	#1,2,3	34	5,504	FA	55	FA	50	#1,2,3
17	4,004	DF	45	DF	36	#1,2,3	35	5,504	FB	55	FB	50	#1,2,3
18	4,004	DG	45	DG	36	#1,2,3	36	5,504	FC	55	FC	50	#1,2,3

Compressor & Shell combinations

Compressor code	Evaporator Code	Condenser Code
A0, A1	AA~AD, BA~BD	AA~AD, BA~BD
A2, A3	AA~AD, BA~BD	AA~AD, BA~BD
B1, B2, B3	AA~AD, BA~BD, CA~CC	AA~AD, BA~BD, CA~CC
C1, C2, C3	BA~BD, CA~CF, DA~DC	BA~BD, CA~CF, DA~DC
D1, D2, D3	BD, CA~CF, DA~DF, EA~EC	BD, CA~CF, DA~DF, EA~EC
E1, E2, E3	CD~CF, DA~DF, EA~EF, GA~GC	CD~CF, DA~DF, EA~EL
F1, F2, F3	DD~DF, EA~EF, GA~GK	DD~DF, EA~EQ
G1, G2, G3	ED~EF, GA~GK, FA~FC	ED~EQ, FA~FC

Vibration isolation & Foundation

Typical isolation

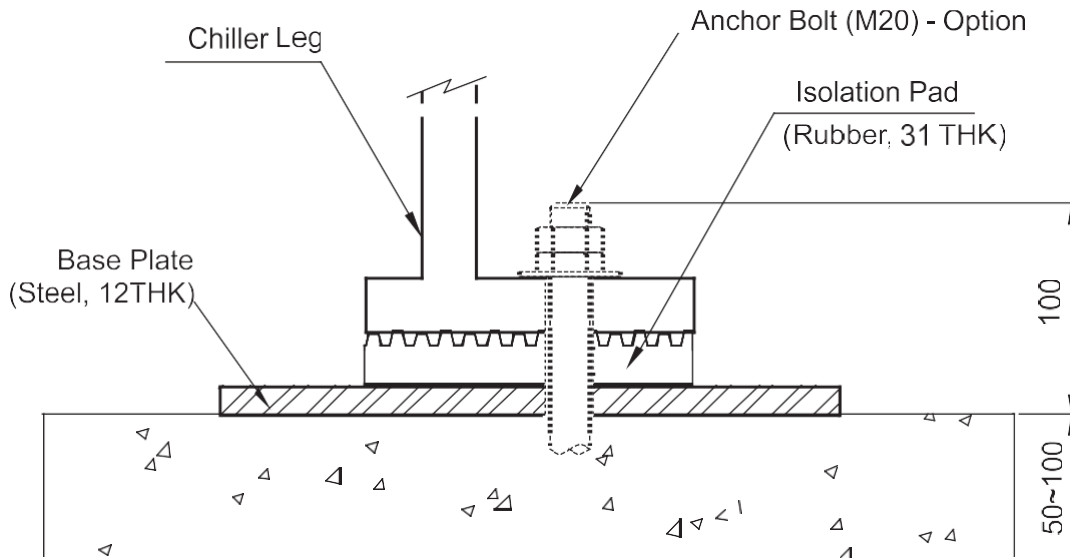

- Notes: 1. Unit is in millimeter
 2. As a standard isolation package, Base plate, Isolation pad and Level plates are supplied.
 3. Foundation height is recommended for piping and drain.

Foundation dimensions

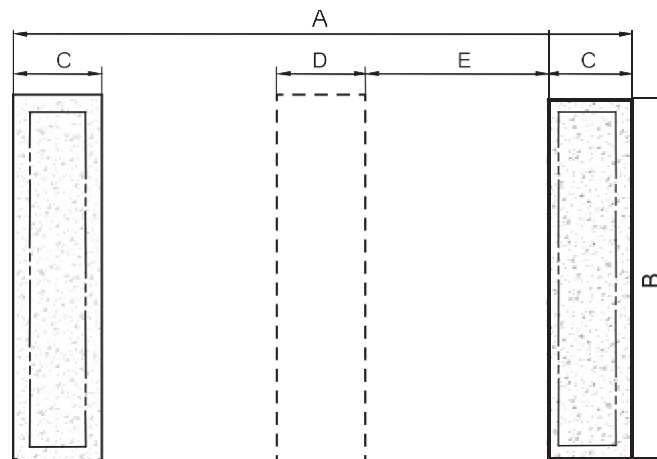

(Unit : mm)

Model Range	A	B	C	D	E
LTP045~055	4,300	1,964	500	n/a	n/a
LTP060~080	4,300	2,250	500	n/a	n/a
LTP090~120	4,300	2,500	500	n/a	n/a
LTP130~200	4,875	3,300	500	n/a	n/a
LTP250~300	7,145	3,300	550	650	2,697

Precaution
 Due to our policy of innovation, some specification can be changed without prior notification

RCWF Series (50/60Hz) / AHRI condition

Model	Cooling Capacity		Input Power [kW]	EEF. kW/RT (full load)	Evaporator				Condenser			
	USRT	kW			Conn. Size (mm)	Flow rate (l/s)	Press. Drop (mH ₂ O)	Passes	Conn. Size (mm)	Flow rate (l/s)	Press. Drop (mH ₂ O)	Passes
RCWFHA0	200	703	120.6	0.603	150	30	3.44	2	150	35	5.02	2
RCWFHA1	250	879	147.8	0.591	150	38	3.45	2	150	44	5.07	2
RCWFHA2	275	967	162.5	0.591	200	42	3.43	2	200	48	5.04	2
RCWFHA3	300	1,055	176.1	0.587	200	46	3.43	2	200	53	5.10	2
RCWFHB1	400	1,407	220.0	0.55	200	61	3.44	2	200	69	5.02	2
RCWFHB2	450	1,583	244.8	0.544	200	68	3.43	2	200	78	5.05	2
RCWFHB3	500	1,758	268.5	0.537	200	76	3.44	2	200	87	5.07	2
RCWFHC1	550	1,934	295.4	0.537	200	84	3.44	2	200	95	5.04	2
RCWFHC2	600	2,110	319.2	0.532	200	91	3.45	2	200	104	5.06	2
RCWFHC3	700	2,462	366.8	0.524	250	107	3.44	2	250	121	5.05	2
RCWFHD1	800	2,813	429.6	0.537	250	122	5.68	2	250	138	8.71	2
RCWFHD2	900	3,165	483.3	0.537	300	137	5.68	2	300	156	7.06	2
RCWFHD3	1,000	3,517	523.0	0.523	300	152	5.68	2	350	172	7.24	2
RCWFHE1	1,100	3,869	590.7	0.537	300	167	6.21	2	350	190	8.76	2
RCWFHE2	1,300	4,572	686.4	0.528	300	198	8.09	2	350	224	11.10	2
RCWFHE3	1,500	5,275	781.5	0.521	350	228	8.09	2	400	258	11.14	2
RCWFHF1	1,600	5,627	884.8	0.553	350	244	6.79	2	400	278	9.58	2
RCWFHF2	1,800	6,330	973.8	0.541	400	274	6.90	2	400	312	9.61	2
RCWFHF3	2,000	7,034	1,072.0	0.536	400	304	6.94	2	450	346	10.55	2
RCWFHG1	2,150	7,561	1,173.9	0.546	450	327	2.15	1	450	373	2.70	1
RCWFHG2	2,350	8,265	1,273.7	0.542	450	358	2.07	1	500	407	2.69	1
RCWFHG3	2,950	10,375	1,631.4	0.553	500	449	2.74	1	500	512	3.41	1

- Note:
1. RT = 3,024 kcal/hr = 3.517kW, 1mmH₂O = 9.8kPa
 2. Operation condition:
 - Evaporator: Entering temperature: 12.2 °C, Leaving temperature: 6.7 °C
 - Condenser: Entering temperature: 29.4 °C, Leaving temperature: 35 °C
 3. The fouling factor of chilled water: 0.018m²·°C/kW
 4. The fouling factor of cooling water: 0.044m²·°C/kW
 5. Due to our policy of innovation, some specification can be changed without prior notification.
All data in this table have been rated in accordance with AHRI Standard 550/590.

Combination

CAPACITY		Comp	Evap.	Cond.	Motor	INPUT POWER	RIGGING WEIGHT	OPERATING WEIGHT	REFRIGERANT
RT	kW					kW	kg	kg	kg
200 ~ 400	700 ~ 1,406	A	AA-CC	AA-CC	4	~280	7,000 ~ 8,300	8,350 ~ 9,450	450 ~ 650
350 ~ 570	1,230 ~ 2,005	B	AA-CC	AA-CC	4	~350	7,900 ~ 9,500	8,85 ~ 11,100	550 ~ 750
480 ~ 785	1,690 ~ 2,760	C	BA-DC	BA-DC	5	~500	8,600 ~ 12,000	9,850 ~ 14,100	650 ~ 900
715 ~ 1,114	2,515 ~ 3,920	D	CA-EC	CA-EC	5~6	~700	11,000 ~ 15,000	12,800 ~ 17,900	750 ~ 1,050
940 ~ 1,635	3,300 ~ 5,750	E	DA-GC	DA-GC	6 ~ 7	~1,000	12,500 ~ 26,200	14,850 ~ 30,600	900 ~ 1,650
1,320 ~ 2,200	4,640 ~ 7,740	F	DF-GG	DF-GG	7	~1,350	19,000 ~ 33,000	22,450 ~ 38,900	1,050 ~ 2,000
2,050 ~ 3,000	7,200 ~ 10,548	G	GA-FC	GA-FC	7	~2,100	30,000 ~ 38,500	35,000 ~ 45,000	2,300 ~ 2,500

Motor electrical data (60Hz)

Max motor power (kW)	150	170	190	220	240	260	280	320	330	350	380	390	420	450	495	500	
Efficiency (%)	-	-	-	-	-	-	-	-	-	-	-	-	-	-	-	-	
Power factor (%)	-	-	-	-	-	-	-	-	-	-	-	-	-	-	-	-	
Torque kg.m	42	47	52	61	66	72	77	88	91	97	105	108	116	125	137	138	
Slip (%)	2.0	2.0	1.9	1.9	1.7	1.9	2.1	1.7	2.2	2.2	2.2	2.2	2.2	2.2	2.2	2.2	
RPM	3,520	3,520	3,530	3,530	3,540	3,530	3,525	3,540	3,520	3,520	3,520	3,520	3,520	3,520	3,520	3,520	
380V	RLA	272	308	346	397	434	471	503	575	602	639	683	721	777	821	903	888
	LRA	1,767	2,001	2,246	2,581	2,822	3,061	3,267	3,734	3,910	4,156	4,439	4,688	5,049	5,338	5,872	5,771
440V	RLA	235	266	298	343	375	407	435	496	518	550	592	623	671	709	780	767
	LRA	1,526	1,728	1,940	2,229	2,437	2,643	2,825	3,225	3,366	3,578	3,846	4,049	4,361	4,610	5,071	4,984
3,300V	RLA	31	35	40	46	51	54	58	66	68	73	78	80	87	93	102	100
	LRA	203	230	260	297	328	353	379	430	443	476	508	519	564	603	663	650
6,600V	RLA	16	18	20	23	25	26	28	32	34	36	39	40	43	46	50	52
	LRA	102	116	129	148	161	172	185	210	221	234	253	263	281	296	326	332
13,800V	RLA	-	-	-	-	-	-	-	-	-	-	-	-	-	-	-	-
	LRA	-	-	-	-	-	-	-	-	-	-	-	-	-	-	-	-

Max motor power (kW)	550	610	670	740	800	900	1,000	1,050	1,100	1,200	1,300	1,400	1,550	1,650	1,750	1,900	
Efficiency (%)	-	-	-	-	93.0	93.2	93.6	93.1	93.7	94.7	94.5	94.9	94.5	93.9	95.6	94.8	
Power factor (%)	-	-	-	-	93.8	94.9	93.0	94.2	95.0	92.6	91.1	91.7	92.2	94.0	93.5	93.5	
Torque kg.m	152	169	185	205	221	249	277	291	304	332	360	387	429	451	479	20	
Slip (%)	2.2	2.2	2.2	2.2	2.2	2.2	2.2	2.2	2.2	2.2	2.2	2.2	2.2	1.1	1.1	1.1	
RPM	3,520	3,520	3,520	3,520	3,520	3,520	3,520	3,520	3,520	3,520	3,520	3,520	3,520	3,560	3,560	3,560	
380V	RLA	977	1,083	1,190	1,314	-	-	-	-	-	-	-	-	-	-	-	
	LRA	6,348	7,041	7,733	8,541	-	-	-	-	-	-	-	-	-	-	-	
440V	RLA	844	936	1,028	1,135	-	-	-	-	-	-	-	-	-	-	-	
	LRA	5,483	6,081	6,679	7,376	-	-	-	-	-	-	-	-	-	-	-	
3,300V	RLA	111	123	136	150	160	180	203	212	222	243	267	285	315	330	378	
	LRA	723	802	881	973	1,040	1,169	1,322	1,379	1,445	1,577	1,736	1,851	2,050	2,148	2,278	2,460
6,600V	RLA	55	62	68	75	80	89	101	105	110	120	133	141	156	164	188	
	LRA	359	402	442	488	517	581	656	684	716	782	863	919	1,016	1,068	1,133	1,225
13,800V	RLA	-	-	-	-	37.8	42.6	48.1	50.1	51.3	57.2	63.2	67.3	74.4	78.2	81.9	89.7
	LRA	-	-	-	-	186.1	209.2	236.2	246.2	252	281.5	310.7	330.8	365.8	384.5	414.0	441.0

Starter type

	Soft starter	Y-delta	Reactor & Kondorfer	Direct	VSD
60Hz	380~13,800V ~2,200kW	380~480V ~750kW	380 ~ 13,800V ~2,200kW	380~13,800V ~2,200kW	380~13,800V ~2,200kW

Combination

CAPACITY		Comp	Evap.	Cond.	Motor	INPUT POWER	RIGGING WEIGHT	OPERATING WEIGHT	REFRIGERANT
RT	kW					kW	kg	kg	kg
200 ~ 400	700 ~ 1,406	A	AA-CC	AA-CC	4	~280	7,000 ~ 8,300	8,350 ~ 9,450	450 ~ 650
350 ~ 570	1,230 ~ 2,005	B	AA-CC	AA-CC	4	~350	7,900 ~ 9,500	8,85 ~ 11,100	550 ~ 750
480 ~ 785	1,690 ~ 2,760	C	BA-DC	BA-DC	5	~500	8,600 ~ 12,000	9,850 ~ 14,100	650 ~ 900
715 ~ 1,114	2,515 ~ 3,920	D	CA-EC	CA-EC	5~6	~700	11,000 ~ 15,000	12,800 ~ 17,900	750 ~ 1,050
940 ~ 1,635	3,300 ~ 5,750	E	DA-GC	DA-GC	6 ~ 7	~1,000	12,500 ~ 26,200	14,850 ~ 30,600	900 ~ 1,650
1,320 ~ 2,200	4,640 ~ 7,740	F	DF-GG	DF-GG	7	~1,350	19,000 ~ 33,000	22,450 ~ 38,900	1,050 ~ 2,000
2,050 ~ 3,000	7,200 ~ 10,548	G	GA-FC	GA-FC	7	~2,100	30,000 ~ 38,500	35,000 ~ 45,000	2,300 ~ 2,500

Motor electrical data (50Hz)

Max motor power (kW)	150	170	190	220	240	260	280	320	330	350	380	390	420	450	495	500	
Efficiency (%)	92.2	92.3	92.1	92.7	92.4	93.0	93.1	92.7	92.0	91.6	92.8	91.2	91.2	90.8	92.1	92.8	
Power factor (%)	91.0	91.0	90.7	91.0	90.9	90.2	90.8	91.4	91.2	90.8	91.1	90.6	90.1	91.6	90.4	92.2	
Torque kg.m	50	56	63	73	79	86	93	106	109	115	125	129	139	149	164	165	
Slip (%)	1.9	1.9	1.9	1.9	1.9	1.8	2.0	1.8	2.1	1.5	1.4	1.6	1.7	1.8	1.9	1.8	
RPM	2,943	2,943	2,945	2,943	2,943	2,946	2,940	2,946	2,937	2,955	2,958	2,952	2,949	2,946	2,943	2,946	
380V	RLA	272	308	346	397	434	471	503	575	602	639	683	721	777	821	903	888
	LRA	1,767	2,001	2,246	2,581	2,822	3,061	3,267	3,734	3,910	4,156	4,439	4,688	5,049	5,338	5,872	5,771
440V	RLA	235	266	298	343	375	407	435	496	518	550	592	623	671	709	780	767
	LRA	1,526	1,728	1,940	2,229	2,437	2,643	2,825	3,225	3,366	3,578	3,846	4,049	4,361	4,610	5,071	4,984
3,300V	RLA	31	35	40	46	51	54	58	66	68	73	78	80	87	93	102	100
	LRA	203	230	260	297	328	353	379	430	443	476	508	519	564	603	663	650
6,600V	RLA	16	18	20	23	25	26	28	32	34	36	39	40	43	46	50	52
	LRA	102	116	129	148	161	172	185	210	221	234	253	263	281	296	326	332
13,800V	RLA	-	-	-	-	-	-	-	-	-	-	-	-	-	-	-	-
	LRA	-	-	-	-	-	-	-	-	-	-	-	-	-	-	-	-

Max motor power (kW)	550	610	670	740	800	900	1,000	1,050	1,100	1,200	1,300	1,400	1,550	1,650	1,750	1,900	
Efficiency (%)	93.2	92.8	93.2	93.1	93.0	93.2	93.6	93.1	93.7	94.7	94.5	94.9	94.5	93.9	95.6	94.8	
Power factor (%)	91.8	91.8	92.7	92.7	93.8	94.9	93.0	94.2	95.0	92.6	91.1	91.7	92.2	94.0	93.5	93.5	
Torque kg.m	182	202	222	246	265	298	331	348	365	398	431	464	515	541	573	622	
Slip (%)	2.0	2.0	2.1	2.2	2.1	2.1	2.0	2.1	2.1	2.0	2.0	2.0	2.2	0.9	0.9	0.9	
RPM	2,940	2,940	2,937	2,934	2,937	2,937	2,940	2,937	2,937	2,940	2,940	2,940	2,934	2,973	2,973	2,973	
380V	RLA	977	1,088	1,179	1,303	-	-	-	-	-	-	-	-	-	-	-	
	LRA	6,349	7,071	7,664	8,468	-	-	-	-	-	-	-	-	-	-	-	
440V	RLA	844	936	1,028	1,135	-	-	-	-	-	-	-	-	-	-	-	
	LRA	5,483	6,081	6,679	7,376	-	-	-	-	-	-	-	-	-	-	-	
3,300V	RLA	111	123	136	150	159	178	202	210	220	240	266	282	313	328	349	381
	LRA	723	802	881	973	1,033	1,157	1,313	1,366	1,430	1,560	1,727	1,836	2,032	2,134	2,268	2,475
6,600V	RLA	55	62	68	75	80	89	101	105	110	120	133	141	156	164	174	188
	LRA	359	402	442	488	517	581	657	684	716	781	863	919	1,016	1,068	1,133	1,225
13,800V	RLA	-	-	-	-	37.8	42.6	48.1	50.1	51.3	57.2	63.2	67.3	74.4	78.2	81.9	89.7
	LRA	-	-	-	-	186.1	209.2	236.2	246.2	252	281.5	310.7	330.8	365.8	384.5	414.0	441.0

Starter TYPE

	Soft starter	Y-delta	Reactor & Kondorfer	Direct	VSD
50Hz	380~13,800V ~2,200kW	380~480V ~750kW	380 ~ 13,800V ~2,200kW	380~13,800V ~2,200kW	380~13,800V ~2,200kW

Interface wiring diagram

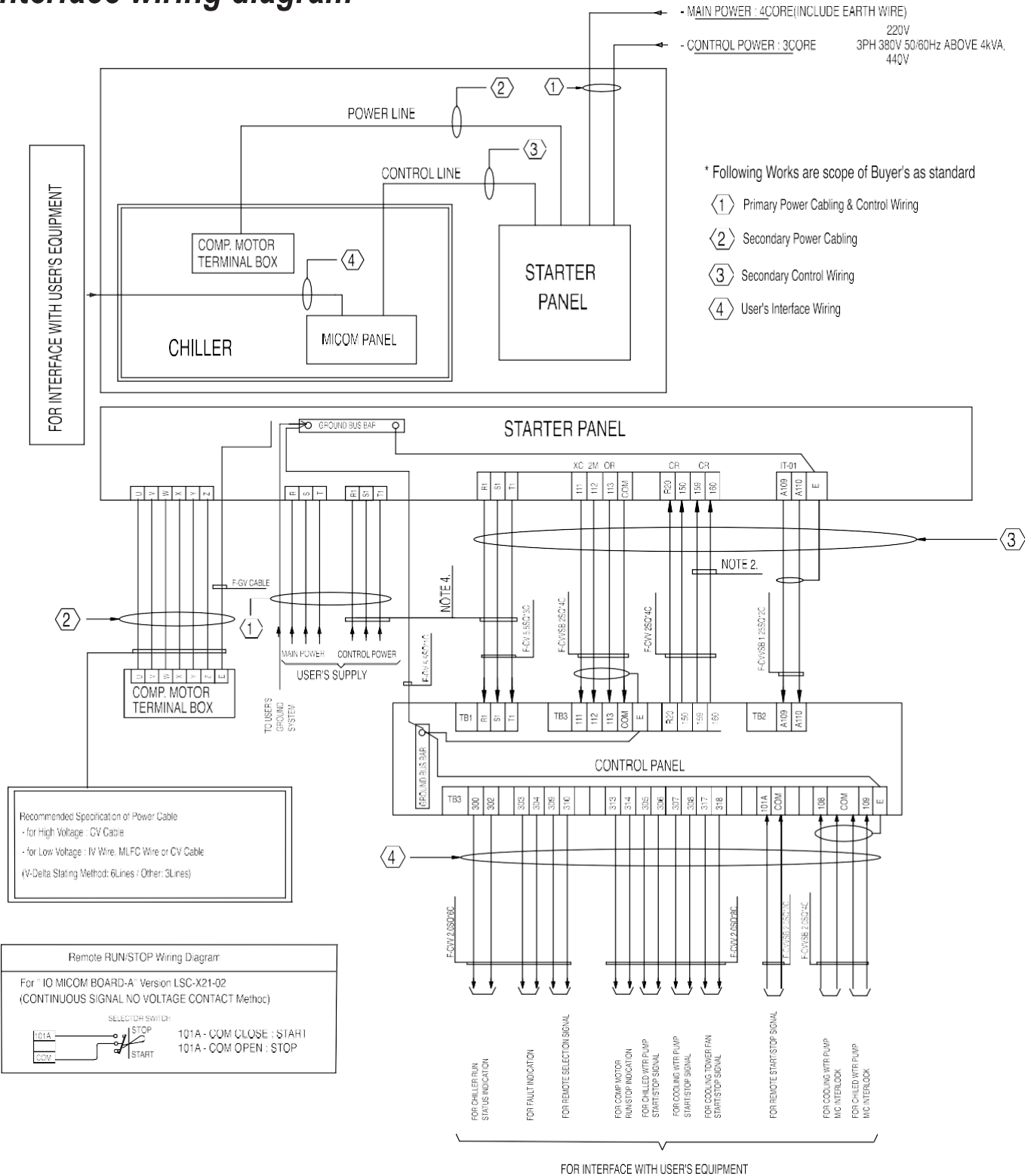

Notes: 1. Only for high voltage starter panel (3300V, 6600V).
 2. Control panel wire should be 2.0mm² or above and control power cable should be 5.5mm² or above.
 3. For other details, refer to certified Schematic Diagram.

Chilled / cooling water piping

- As a standard, 10kg/cm² of flange is adopted for evaporator and condenser nozzles.
- The inlet nozzle is located on the lower side and the outlet is positioned on the upper side as a standard.
- All piping should be supported independently in order not to convey any stress and vibration onto the Chiller and have sufficient space for maintenance purpose.
- On each water box of evaporator and condenser, it is requested to install air-vent cock, drain valve and piping as well.
- It is strongly to install strainers on each inlet of evaporator and condenser in order to filter foreign materials. If the foreign materials are flowed into the heat exchanger, there is high possibility of freezing.
- It is recommended to install thermometer, pressure gauge and flow meter to measure the chiller operational condition.

Control of cooling water temperature

As a standard, 10kg/cm² of standard flange is adopted for evaporator and condenser nozzles. In general, if the atmospheric temperature falls below than design the temperature of condition cooling water from the cooling tower decrease as well. Therefore, for whole-year-operation chillers, it is strongly recommended to control the cooling tower fan according to outlet temperature of cooling tower and adopt by-pass system in parallel. The by-pass system is positioned on the outlet of cooling water and bypass the cooling water through 3-way control valve working at condensation pressure.

The 3-way control valve can be alternated with 2 units of butterfly valve. The system should maintain min. 14°C of temperature difference between cooling water outlet and chilled water outlet.

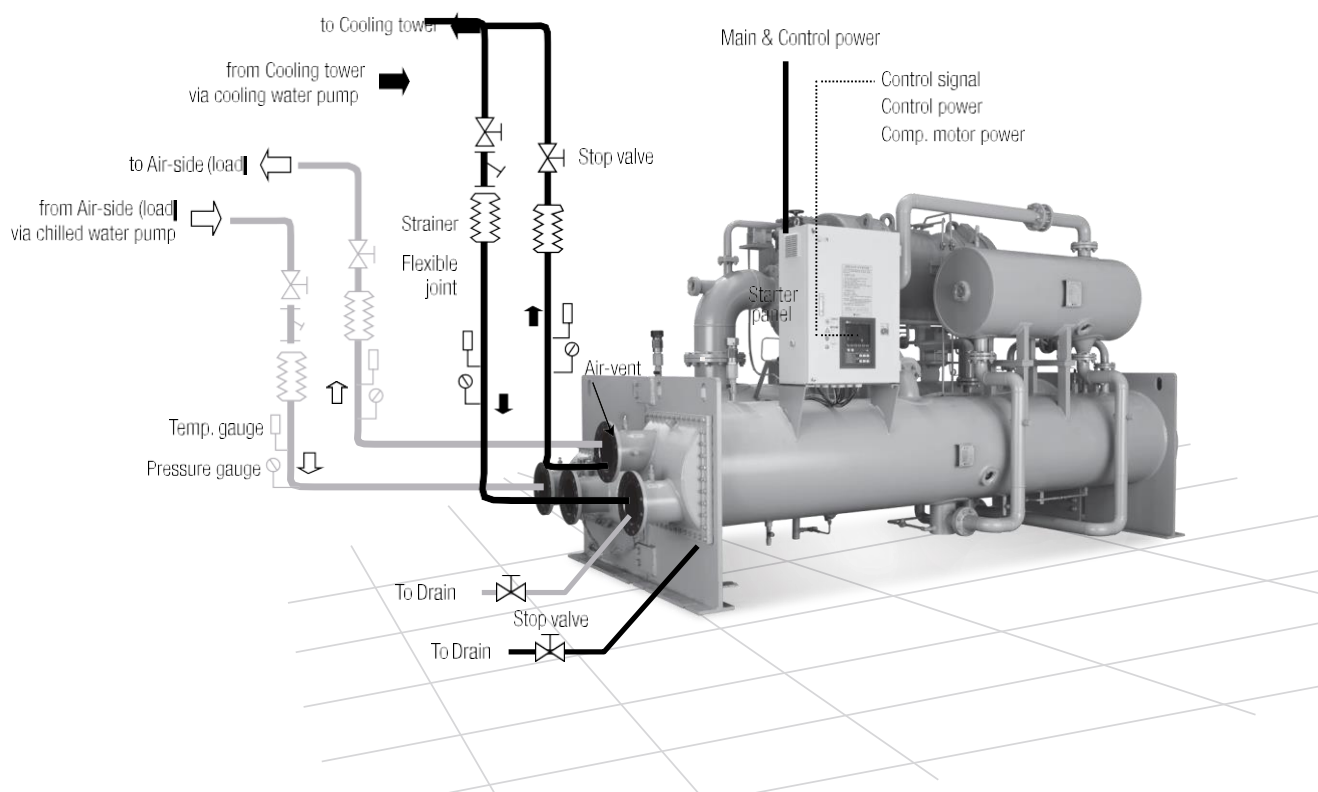

- Notes: 1. Control power - 3Phase/220V/50Hz(60Hz) - should be provided by the customer apart from main power source.
 2. The Main power wiring to the starter and 2nd wiring between the chiller and starter must be done based on local regulation. And the work scope is purchaser's.

Nozzle arrangement (Evaporator)

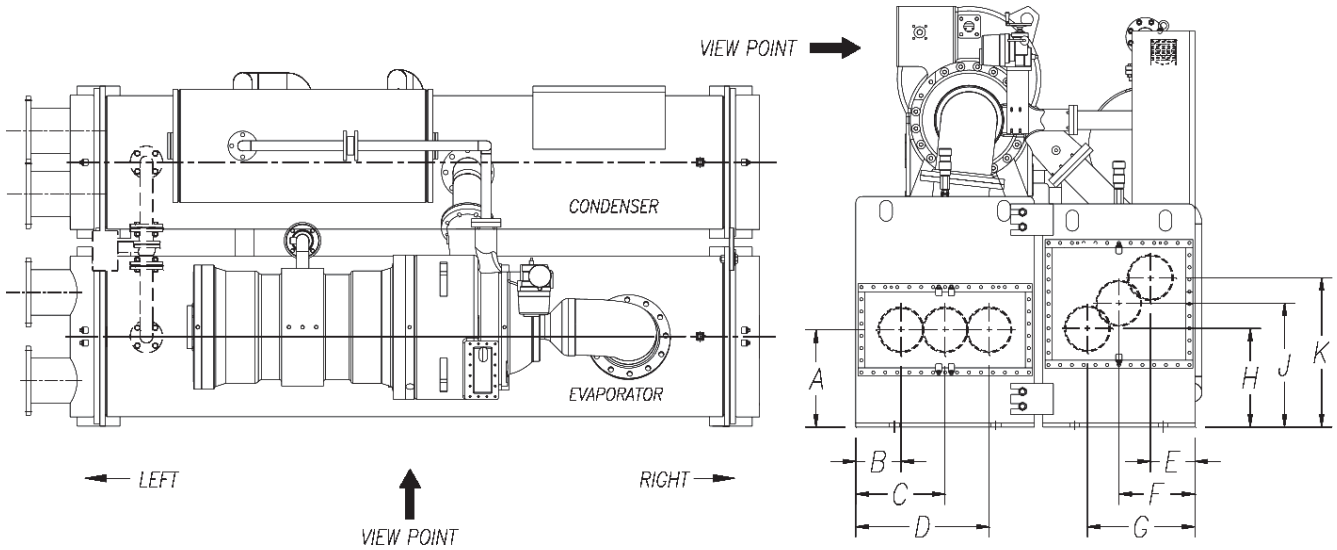

(Unit : mm)

COMP. CODE	HEX CODE	Flange Size			1 Pass		2 Pass			3 Pass		
		1 Pass	2 Pass	3 Pass	C	A	B	D	A	B	D	A
					Left & Right	Height	Left Nozzle Inlet	Left Nozzle Outlet	Height	Left Nozzle Inlet	Right Nozzle Outlet	Height
A	A	250	150	150	426	463	216	636	463	216	636	463
	B	250	150	150	505	481	215	675	481	215	675	481
	C	250	200	150	505	481	215	675	481	215	675	481
B	A	300	200	150	426	463	216	636	463	216	636	463
	B	300	200	150	505	481	215	675	481	215	675	481
	C	300	200	200	505	481	215	675	481	215	675	481
C	B	350	200	200	505	481	215	675	481	215	675	481
	C	350	200	200	505	481	215	675	481	215	675	481
	D	350	250	200	571	538	230	770	538	230	770	538
D	C	400	250	200	505	481	215	675	481	215	675	481
	D	400	300	250	571	538	230	770	538	230	770	538
	E	400	300	250	576	574	296	856	574	296	856	574
E	D	400	300	250	571	538	230	770	538	230	770	538
	E	450	300	250	576	574	296	856	574	296	856	574
	F	500	350	300	642	649	342	942	649	342	942	649
F	G	500	350	300	642	649	342	942	649	342	942	649
	E	550	400	350	576	574	296	856	574	296	856	574
	F	600	400	350	642	649	342	942	649	342	942	649
G	G	450	350	300	642	649	342	942	649	342	942	649
	H	450	350	300	742	709	409	1,075	709	409	1,075	709
	J	600	450	350	842	696	442	1,242	696	442	1,242	696
	K	450	400	350	772	1,225	-	-	-	-	-	-

Nozzle arrangement (Condenser)

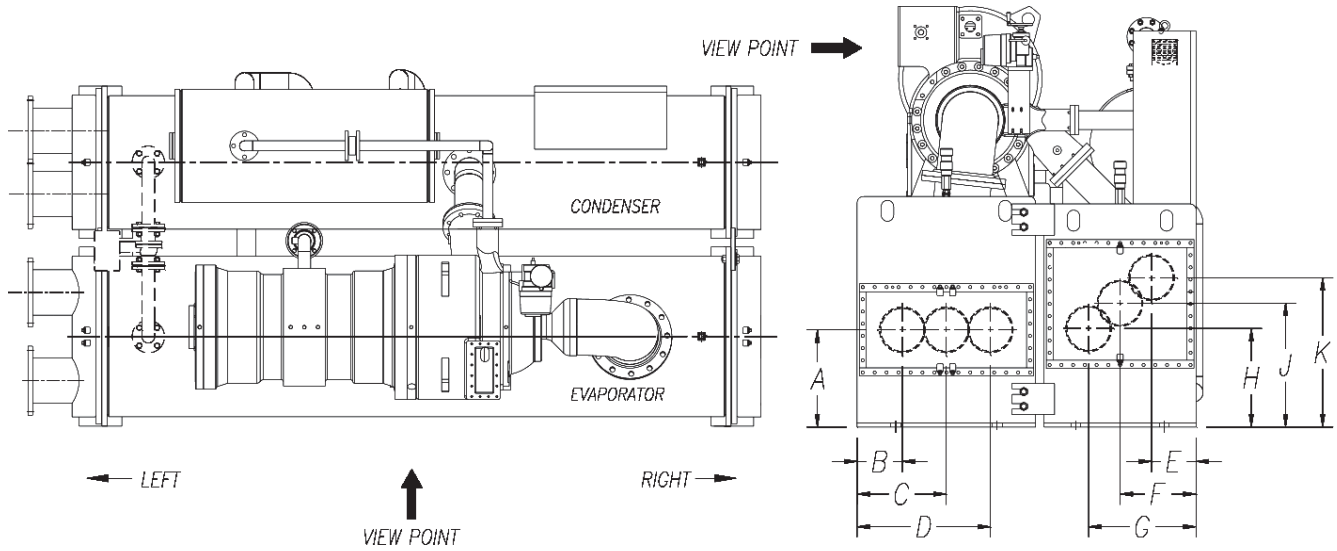

(Unit : mm)

COMP. CODE	HEX CODE	Flange Size			1 Pass		2 Pass				3 Pass			
		1 Pass	2Pass	3 Pass	F	J	G	E	H	K	G	E	H	K
					Left & Right	Height	Left Nozzle Inlet	Left Nozzle Outlet	Inlet Height	Outlet Height	Left Nozzle Inlet	Right Nozzle Outlet	Inlet Height	Outlet Height
A	A	250	150	150	363	587	213	513	463	711	213	513	463	711
	B	250	150	150	417	679	252	582	559	799	252	582	559	799
	C	250	200	150	417	679	252	582	559	799	252	582	559	799
B	A	300	200	150	363	587	213	513	463	711	213	513	463	711
	B	300	200	150	417	679	252	582	559	799	252	582	559	799
	C	350	200	200	417	679	252	582	559	799	252	582	559	799
C	B	350	200	200	417	679	252	582	559	799	252	582	559	799
	C	350	200	200	417	679	252	582	559	799	252	582	559	799
	D	400	250	200	444	641	264	624	486	796	264	624	486	796
D	C	400	250	200	417	679	252	582	559	799	252	582	559	799
	D	400	300	250	444	641	264	624	486	796	264	624	486	796
	E	450	350	250	495	720	315	675	548	892	315	675	548	892
E	D	450	350	250	444	641	264	624	486	796	264	624	486	796
	E	500	350	300	495	720	315	675	548	892	315	675	548	892
	F	550	400	350	540.5	770	313	768	576	964	313	768	576	964
F	G	550	400	350	568.5	770	341	796	576	964	341	796	576	964
	E	600	400	350	495	720	315	675	548	892	315	675	548	892
	F	650	450	400	540.5	770	313	768	576	964	313	768	576	964
	G	500	400	350	568.5	770	341	796	576	964	341	796	576	964
	H	500	400	300	642	897	352	932	677	1,117	352	932	677	1,117
G	J	650	450	350	642	908	352	932	688	1,128	352	932	688	1,128
	K	500	450	400	712	1,225	-	-	-	-	-	-	-	-

Materials

Item	Material	Specification (Equivalent)
Shell Plate	Hot rolled steel	SA 516 Gr. 70
Tube Sheet	Hot rolled steel	SA 516 Gr. 70
Water-box	Hot rolled steel	SA 516 Gr. 70
Tubes	Finned copper tube	SB 359 C12200
Discharge and Suction	Steel	SA 106 Gr. B
Impeller	Al alloy	SB 209
Impeller Casing	Cast iron	SB 48
Pipe	Steel	SA106 Gr. B
Flange	Steel	SA 516
Support	Steel	SA 516 Gr. 70

Notes: 1. Specification is an equivalent code in ASME (American Society of Mechanical Engineers)

Insulation

The factory insulation shall include evaporator; suction line up to the compressor suction housing; compressor motor and motor cooling return lines. The insulation shall be completed with 20mm thick of rubber sponge .

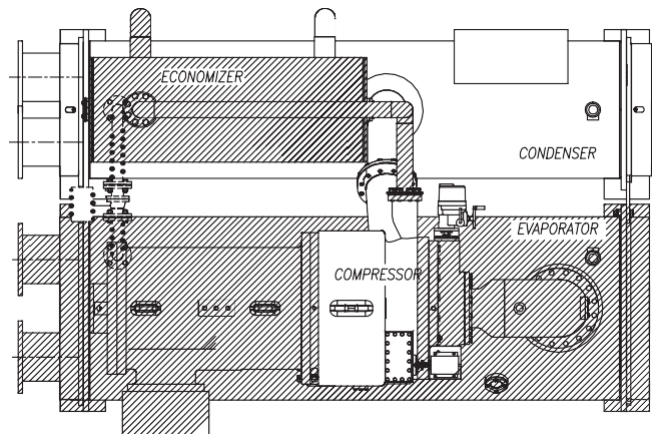

Top View

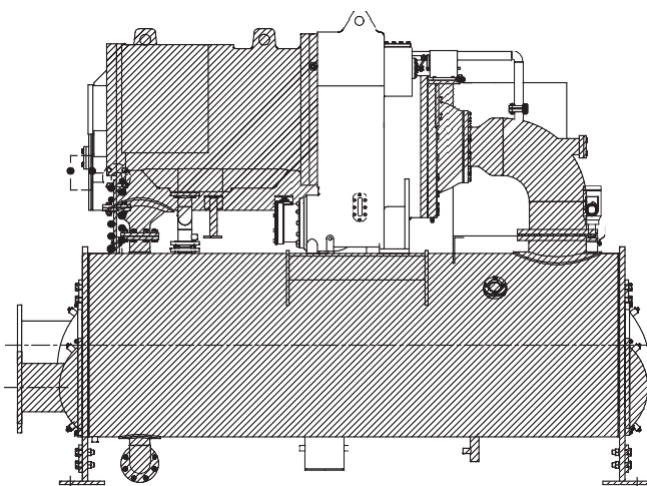

Front view

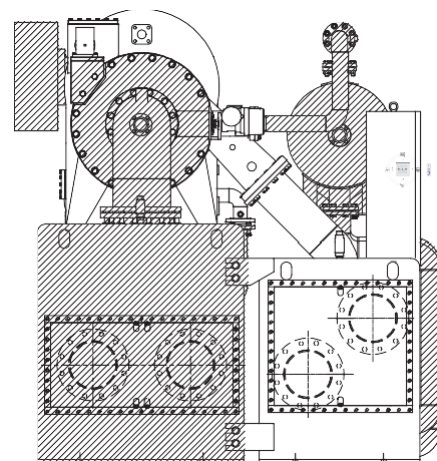

End view

Guide specification

Centrifugal chiller RCWF H series (2-stage, HFC-134a)

Contents

Part 1. Range of application

Part 2. General information

Part 3. Equipment specifications

Part 4. Scope of construction

Part 5. Scope of supply

Part 6. Warranty & svc

Part 7. Notes

Part 1. Range of application

This guide specifications is applied to all the models of the two-stage HFC-134a centrifugal chillers(RCWFH**) manufactured and supplied by LGElectronics.

Part 2. General information

2.1 System structure

- 1) The high-efficiency centrifuge chiller shall use a cycle of 2-stage compression and 2-stage expansion. It shall also use a variable capacity diffuser at the rear end of the 2-tage impeller so that it can work stably even under lower load.
- 2) Economizer shall be an external type for easy maintenance and the condenser shall include an independent sub-cooled heat exchanger. .
- 3) The refrigerant level controller installed in the condenser and economizer shall be controlled by a micom to provide a cycle so that high efficiency can be achieved under full load and partial load.
- 4) The compressor shall be an semi-hermetic type to secure reliance for refrigerant leakage and the motor shall be cooled by a method that uses system refrigerant to guarantee the stability of the product.

2.2. Performance and quality

- 1) The product shall satisfy the performance requirements of AHRI (Air Conditioning, Heating And Refrigeration Institute) Latest Standard 550-590/551-591.
- 2) As the refrigerant, R-134a, environmental refrigerant with Ozone Depleting Potential (ODP) of zero, shall be applied.
- 3) The pressure vessel shall be designed and inspected in accordance with KGS Code(High-Pressure Gas Safety Control Act) or ASME SEC. VIII (Options) and certified by the relevant certification agency.

Part 3. Equipment specification

3.1 System structure

The chiller is composed of compressor/motor, evaporator, condenser, external-type economizer, oil system, expansion valve, inlet guide vane, refrigerant piping, control panel, starter, safety device, and insulation/isolator.

3.2 Compressor/motor

- 1) The compressor is a high-efficiency semi-hermetic and centrifugal 2-stage type for HFC-134a. The impeller is made of high-strength special aluminum alloy and integrated with the Return Channel oil flow path loss optimization provided between 1st and 2nd impellers for minimization of efficiency loss and easy service.
- 2) The motor shall be a liquid refrigerant-based cooling type and insulated by anti-humidity materials to prevent condensation. It shall be able to respond to 380-13,800V,

50/60Hz and 3Ph. The motor shall have a high-efficiency both-end support structure and has a built-in motor coil temperature sensor for real-time control by the control panel.

- 3) The motor coil shall be specially insulated to have a refrigerant resistance for HFC-R134a an oil resistance for the applied oil
- 4) A variable diffuser shall be adopted for optimized partial load efficiency and stable operation for low load surge. And an independent control motor should be provided to interface with IGV opening.
- 5) A ball or tilting bearing should be applied. It should include an independent oil tank for constant lubrication for some time after both the pump and compressor stop.
- 6) The inlet guide vane should have multiple vanes to minimize the flow loss at the entrance of the impeller.
- 7) For a stable operation of high-speed axis bearing, two (including one for spare) bearing temperature sensors shall be installed to monitor and manage the temperature in real time.

3.3 Oil system

- 1) A trochoid type semi-hermetic oil pump shall be adopted for constant and stable oil supply for low noise/vibration, while allowing the oil volume control by the control valve.
- 2) The motor for the oil pump shall be insulated to be refrigerant resistant to HFC-134a and oil resistant to the applied oil. It should be a built-in type and structured to supply oil to the pump always stably from the oil tank.
- 3) The oil filter shall be made removable by installing the valve at the entrance and it should include the purge valve and drain plug.
- 4) The oil cooler shall include an external type and plate type heat exchanger, which is durable and easy for maintenance, at the rear end of the filter.
- 5) The oil heater shall be controlled to keep the optimal oil temperature and allow the oil heater only to be replaced.
- 6) The gas piping for the refrigerant, which is to be returned from the oil, tank shall include an external type oil separator to minimize the oil flow to the heat exchanger.

3.4 Evaporator, condenser (including subcooler) and economizer

- 1) The evaporator and condenser shall have a shell & tube structure and include a high-efficiency heat pipe. The heat pipe shall be installed as a mechanical expanding pipe and be removable for service. The hole part for the heat pipe on the tube plate shall have 2 grooves for protection from leakage.
- 2) The evaporator shall have a 10mm or less perforated plate structure which can distribute the refrigerant evenly, with a distributing valve at the entrance. A valve shall be installed

- at the refrigerant gas entrance to prevent liquid carry-over.
- 3) The condenser shall have a collision prevention valve, at the gas inlet, which allows noise reduction and stable expansion of oil flow path. Also a liquid separator shall be installed in the center of top-bottom arrangement. To secure the subcooling temperature, the subcooler shall be an independently installed with a built-in condenser, with condensation and subcooling spaces separated.
 - 4) The heat-transfer tube shall be processed to encourage heat transfer performance inside and outside the tube and parts in contact with tube plate and tube support plate shall not be processed. The support plate for heat-transfer tube shall be designed for stable support in accordance with TEMA and ASME standards.
 - 5) The pressure vessel shall be designed and inspected in accordance with KGS Code(High-Pressure Gas Safety Control Act) or ASME SEC.VIII (Options) and certified by the relevant certification agency.
 - 6) On the top of the evaporator and condenser, a safety valve shall be installed in accordance with KGS Code(High-Pressure Gas Safety Control Act) or ASME SEC.VIII (Options).
 - 7) The water box shall be designed to select 10kg/cm², 16kg/cm², or 20kg/cm² according to the water pressure with a structure of air vent on the top and drain on the bottom. The water box for 16kg/cm², 20kg/cm² shall be structured to secure high strength and reliance at high pressures.
 - 8) The economizer shall be an external type that allows service and operation management. Inside the economizer, the liquid and gas shall be fully separated. The eliminator shall be installed at the gas outlet to prevent liquid carry-over.

3.5 Refrigerant level and flow controller

- 1) The condenser and economizer shall be equipped with the level control sensor to keep an optimal cycle under full or partial load. It shall control two refrigerant flow control valves installed in the liquid pipe to keep the refrigerant optimal in each cycle.
- 2) The refrigerant level control sensor shall have a shut-off valve to for easy service and maintenance without the extraction of refrigerant in the inspection.
- 3) The condenser shall store some refrigerant under partial load, to allow stable motor cooling and oil cooling even during low temperature cooling operation.

3.6 Control panel

- 1) Structure
The control panel shall consist of Micom module (main module, an I/O module, and an indication and operation key module), a power supply for supplying stable power, breakers for controlling and safety, an electronic contact, and relays for controlling.

2) Main module

The module shall use the high-performance microprocessor to perform the control function optimized for the equipment. The high-precision analog/digital (A/D) converter shall measure the values of the temperature sensors to display the values on the screen, and apply them to the controlling. The RS-485/232C communication port is embedded by default to support the remote monitoring and controlling by customers. Customers simply select RS-485 or RS-232C for their building automation.

3) Indication and operation key module

The indication and operation key module consists of a display indicating operating data, set points required for the equipment operation, and data of abnormality in characters; a key input section for entering the data or selecting menus; and a LED lamp indicator section showing the equipment operation shutdown conditions important for the operation of the equipment, the operation of the compressor, the oil pump, the oil heater, the flow of chilled water/cooling water, problems, the selected manual actuation of the vanes, and the selected manual operation of the oil pump. In particular, the module allows operators to directly access the frequently used keys, and select other operations from the menu for improving the convenience of operators. The operation keys consist of: four menu operation keys, three manual operation keys for the vanes, three manual operation keys for the oil pumps, and two operation/shutdown key for the operation and the shutdown of the equipment. If the operation keys are inoperable, operators shall be able to use the character display and the menu selection keys to operate the equipment from the menu. The display shall show the following operation conditions in Korean, Chinese or English: the temperature of the inlet and the outlet of the chilled water and the cooling water, the compressor discharge temperature, the oil tank temperature, the motor bearing temperature, the condenser pressure, the evaporator pressure, the oil tank pressure, the oil pump pressure, the operating current and the vane opening.

4) I/O module

The I/O module consists of a digital input section for monitoring the operating conditions of the switches and a digital output section for controlling the operation of the equipment. A photo coupler is mounted on the I/O section for preventing noises, and receives/transmits all the data through communication with the main module to prevent malfunctions caused by electronic waves generated from the data transmission through the cables.

3.7 Features of controller

1) Convenient operation data management

A large LCD (16 Korean characters in 8 lines) is used to display various pieces of operation information on a single screen, and stores the analog data (e.g., temperature data) up to 300 cases per channel in the intervals defined by customers for

keeping daily operation logs. The real-time display also shows the temperature of the chilled water outlet and the operating current of the compressor motor in graphics for easily identifying the trends of the changes to the temperature and operating current.

2) Self-diagnosis and failure history storing

The micom monitors the conditions of the equipment during shutdown and operation, and notifies operators of the conditions of the equipment by displaying characters, alarm lamps and buzzers, and stores the time and the log of failures for maintenance. In particular, The micom classifies failures into minor failures and major failures. If a minor failure takes place, the micom displays the details of the failure in characters and continues the operation of the equipment to minimize the shutdown of the equipment.

3) Optimized artificial intelligence control algorithm for chiller control

• Flexible Startup

The vane is slowly operated to prevent impacts on the equipment such as the surge generated from a rapid increase in load at the startup of the equipment.

• Digital PID Control

When the manual mode is changed to the auto mode, the digital PID control integrated with the flexible startup shall recognize the optimal PID control points automatically to minimize the unnecessary shutdown of the equipment and reflect them to the control equation to control the temperature stably and precisely.

• Preventive Operation

The temperature and the pressure of the components are measured in real-time during operation and the primary and secondary preventive operations are performed in accordance with the measurement results to prevent the shutdown of the chiller caused by the overload, the high pressure of the condenser, the low pressure of the evaporation, and surges.

• Scheduled operation

The scheduled operation function is provided for the convenient operation of the equipment, which allows the selection of the operation/shutdown and the setting of the control temperature per day of the week, per holiday or 11 times a day

• Service functions

The following service functions are supported for easy maintenance:

※ Automatic sensor setting of the sensors by using software.

※ Step control of the cooling tower fan for keeping the cooling water temperature stably. (The inverter control is optional)

※ Displaying the count of startups and the total operation hours of the pumps and the motors mounted on the body.

※ Printing the operation and the trouble data. (Optional)

4) Powerful customer support functions

• Help

The help function memorizes the details of failures and shows

the descriptions for corrective actions when the operator selects a particular failure from the menu, in order to improve the convenience for operators.

- Communication for building automation and remote monitoring and control The communication function is embedded by default (RS232C/RS485) for connecting the equipment with the monitoring system of customers. The zero-voltage I/O function is provided for remote operation and shutdown by using a simple electric wiring, or for monitoring the operating conditions of the equipment. In addition, BACnet or Ethernet are optionally mounted for improving the operation of the equipment for the convenience of customers.

5) Indicator lamp

All indications are displayed in characters on the LCD which turns on in the following 8 cases.

- Chiller operates/shuts down
- Compressor operates
- Oil pump operates
- Oil heater operates
- Chilled water flow normal
- Cooling water flow normal
- Vane manual
- Oil pump manual

3.8 Starter

- 1) The starter is a standalone closed starter equipped with the embedded EOCR-3DS protective relay for over-current, short, phase loss, reverse phase, unbalance and restrictions. The starter is mounted with the following components: a voltmeter, an ammeter, a voltage selection switch, a current selection switch, a power indicator lamp, an operation indicator lamp, an alarm indicator lamp, a shutdown indicator lamp, a breaker for protecting circuits, and a RESET switch.

2) Protective relay

EOCR-3DS protective relay should be installed. (over-current, short, phase loss, reverse phase, unbalance and restrictions)

- ※ The Ground fault circuit interrupter is optional and will be installed as required by customers.

3) Operation and instrument panel

Indicator lamps, breaker for protecting circuits, voltmeter, ammeter, voltage and current phase conversion switch

4) Indicator lamp: turns on in the following three cases.

- Power indicator lamp (white)
- Operation indicator lamp (red)
- Shutdown indicator lamp (green)

3.9 Safety devices

- 1) Chilled Water Low Temperature [temperature sensor at chilled water outlet] _ Protect the evaporator from freeze.
- 2) Evaporator Low Pressure [evaporator pressure sensor] _

Protect evaporator from abnormal low pressure

- 3) Condenser High Pressure [condenser pressure sensor] _
Protect chiller from abnormal high pressure condenser
- 4) Motor High Temperature [motor temperature sensor] _
Protect motor from abnormal high temperature coil
- 5) Bearing High Temperature [bearing temperature sensor] _
Protect compressor from abnormal temperature bearing
- 6) Oil Differential Low Pressure [oil tank & discharge-side pressure sensor] _ Protect compressor from abnormal oil supply differential pressure
- 7) Oil High Temperature [oil tank temperature sensor] _
Protect compressor from high oil temperature
- 8) Oil Low Temperature [oil tank temperature sensor] _
Protect compressor low oil temperature
- 9) Chilled Water Pump Abnormal [interlock with chilled water pump] _ Protect chiller from chilled water pump
- 10) Cooling Water Pump Abnormal [interlock with cooling water pump] _ Protect chiller from abnormal cooling water pump
- 11) Chilled Water Flow Rate Abnormal [chilled water differential pressure switch] _ Protect chiller from abnormal chilled water flow rate
- 12) Cooling Water Flow Rate Abnormal [cooling water differential pressure switch]_ Protect chiller from abnormal cooling water flow rate (optional)
- 13) Surge Abnormal [control panel] _ Protect compressor from surges
- 14) Oil Pump Over-Current [over-current relay] _ Protect compressor from motor/oil pump over-current
- 15) Motor Reverse Phase/Phase Loss/Over-Current _ Protect chiller from motor reverse phase / phase loss / over-current
- 15) Safety Valve [evaporator/condenser] _ Discharge chiller protective refrigerant when the pressure is abnormally high
- 14) Current Limiting Function [control panel] _ Operation current limited operation, compressor protection / user convenience

※The temperature of the cooling water shall be adjusted to keep the temperature difference 14 °C or higher between the chilled water outlet and the cooling water outlet.

3.10 Isolator

The isolator consists of the sandwiched vibration proof pads of rubber and cork in accordance with the standards. An optional special isolator spring shall be applied if the structure that supports the chiller can easily vibrated by the chiller (optional).

3.11 Cold insulation

- 1) A 20mm or deeper anti-humidity rubber material which is equal or exceeds KS shall be applied, provided that the material and depth shall be able to adjust for prevention condensation by the requirements of the customer or

usage conditions.

- 2) Cold insulation section: evaporator, economizer, compressor motor, water box for chilled water, etc.(follow the cold insulation work plan)

3.12 Start-up commissioning

- 1) A LG engineer or an engineer for the start-up commissioning shall carry out start-up commissioning and provide the operation training.
Provide capacity control system capable of reducing unit capacity to 25% of full load.

Part 4. Scope of construction

Items	Supplied By	Notes
Painting	LGE	Body : Morning gray Starter panel : 7.5BG 6/1.5 Control panel : Warm gray
Cold insulation	LGE	Cold-insulate the external side of evaporator, chilled water box, and motor. The material shall be noncombustible and anti-humidity rubber sponge and 20mm deep
Transportation and installation	LGE	Transportation to the installation site or foundation and installation
External piping	Customer	External piping work for chilled water, cooling water and drain
Control system wiring (on the secondary side)	Customer	Control wiring between the starter panel and the control panel
Power system wiring (on the secondary side)	Customer	Power and ground wiring between the chiller and the starter panel
Control power	Customer	Control power of 3ph, 380V shall be supplied to the starter panel. (minimum power capacity: 4kVA)
Building and foundation	Customer	Completing the foundation construction prior to installing the chiller
Leveling the chiller	LGE	Work performed during the installation of the chiller
Interlock wiring of the chilled water pump and the cooling water pump	Customer	Wiring between the control panel and the pump control panels
Relief valve vent piping	Customer	Piping for discharge of refrigerant in emergency
Permit for high pressure gas	LGE	Permit procedures and cost for relocating the chiller

Part 5. Scope of supply

Items	Supplied By	Notes
Centrifuge chiller body	LGE	Refer to the body components
Refrigerant (R-134a)	LGE	Delivery with refrigerant charged (Divide or deliver separately if required)
Lubrication oil	LGE	Delivery with oil charged
Isolator Pad	LGE	Vibration absorption pad
Spare parts	LGE	Spare parts supplied as standard
Chiller manual	LGE	Installation and operation manual
Leveling plate	LGE	Parts for leveling the centrifuge chiller
Starter panel	LGE	compressor motor starter (Customer may select)

Part 6. Warranty & SVC

6.1 *The warranty period shall be the earlier of the following two: “1.5 years of product delivery” or “one year of start-up commissioning.*

6.2 *An failure, caused by a defect in the parts, material, or operation caused during the warranty period, will be inspected by LG ELECTRONICS and fixed free of charge if we agree that it is defective.*

6.3 Warranty is not applicable for the following cases

- 1) If a failure occur after the product is repaired at the shop that is not designated by LG.*
- 2) If the failure is caused by user's mistakes in using and handling the equipment.*
- 3) If the product is resold or transferred to others during the warranty period.*
- 4) If a failure caused due to a fire or a natural disaster.*

Part 7. Notes

7.1 *All specification about the manufacturing shall be submitted to the customer side to get the approval from them before the chiller manufacturing can be started. Any requirement not specified here shall be discussed with and approved by the customer before execution.*

7.2 *When reselling or transferring the product to another party before discarding them, notify LG Electronics*



Ver. 201505

LG Electronics, Home appliance & Air solution company

Two IFC, 10 Gukjegeumyung-ro, Yeongdeungpo-gu, Seoul, 150-945, Korea.

www.lg.com

www.lgearcon.com

For continual product development, LG reserves the right to change specifications or designs without notice.

© 2015 LG Electronics. Printed in Korea. May. 2015